

DC-500_{PN 10}



Backflow Preventer -Double Check Valve

Description

The DC-500 Double Check Valve is designed to provide the best protection and durability against backflow caused by negative pressure or backpressure. Backflow may cause infiltration of chemicals, fertilizers and/or other pollutants into potable water systems. The DC-500 is reliable and easily maintained without the need for special tools.

The DC-500 has two independent, easily replaceable, spring check valves in capsules.

The DC-500 is recommended in places where the degree of pollution doesn't necessitate the use of an RP-500.

Operation

The Double Check Valve (DC-500) device consists of two independently acting, spring-loaded, check valves. Two resilient seated shut-off valves and four test cocks complete the assembly. Each check valve is designed to maintain a minimum of 1 PSI across the valve during normal operation. If at any time, the pressure downstream of the device increases above the supply pressure, both check valves will close to prevent any backflow from occurring.

Applications

- Chemical and fertilizer systems in landscape and agriculture.
- Swimming pools.
- Dairies and poultry coops.
- Food processing plants.

Main Features

- Working Pressure: 10 bar.
- Sizes: 3/4", 1", 1 1/2", 2".
- Working Temp Range: 0.5° to 45° C.
- Made of composite plastic material, resistant to corrosion, scaling, fertilizers, herbicides, insecticides, etc.
- Internal control system ensures reliability and safety.
- Easy and quick installation.
- Economical to operate.
- Lightweight.
- UV resistant.
- Low Head-Loss.
- Meets international standards.
- Specially suited for plastic piping.
- Variety of installation options.
- Long working life with easy maintenance.

The ARI DC-500 is approved by the following Standards

authorities: ASSE 1015, AWWA, NSF 61, Water Mark (Australia), AS2845.1., ACS (France), Approved by the Foundation for Cross Connection Control and Hydraulic Research at the University of Southern California (USC), Listed to Uniform Plumbing Code.



Installation

- Install the DC-500 Double Check Valve in a location accessible for periodic field testing and maintenance.
- Before installing the DC-500, thoroughly flush all upstream piping to remove debris.
- Mount the DC-500 in a horizontal position with adequate clearance from walls and/ or obstructions. A clearance is needed between the lowest portion of the device and floor.
- When the shut-off valves are supplied separately, install them with a Test Cock on the Inlet Shutoff Valve.
- It is recommended that a "Y" strainer be installed before the inlet of the RP-500 to prevent debris from entering the device.
- After installing the assembly, close the Outlet Shut-off Valve, pressurize the DC-500 and release the air through Test Cock #4. Then, open the Outlet Shut-off Valve.

Recommendations

- Do not install in areas subject to extended periods of freezing temperatures.
- The product must be protected from excessive pressure increases caused by thermal expansion or water hammer. They can damage the valve.
- DO NOT USE ANY PIPE DOPE, OIL GREASE OR SOLVENT ON ANY PARTS unless instructed to do so.
- Parts should fit together freely. Do not force parts to fit.

Trouble Shooting Guide

Symptom	Cause	Corrective Action
Check valve fails to hold 0.07 bar.	<p>A. Outlet shut-off valve not closed completely.</p> <p>B. Outlet check valve fouled with debris.</p>	<p>A. Close outlet shut-off valve or inspect for possible through leakage</p> <p>B. Inspect and clean the seat and seal of outlet check valve.</p>

DIMENSIONS AND WEIGHT

Nominal Size	Dimensions mm			Weight Kg.
	A	B	C	
1/2" 3/4" 1"	197	100	99	0.74
1 1/4" 1 1/2" 2"	332	151	157	2.4

* Dimensions and weight without shut-off depends on shut-off valve model.

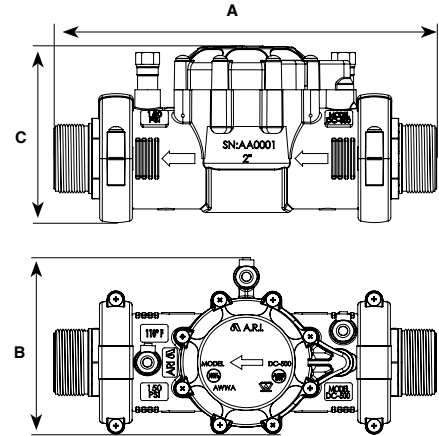

PARTS LIST

No.	Part
1.	Cover Assembly
2.	Retainer
3.	Outlet Check Valve Assembly
4.	Body Seal
5.	Inlet Check Valve Assembly
6.	Test Cocks (#1, #2, #3)
7.	Body Assembly
8.	Adaptor Assembly
9.	Clamp Assembly
10.	Inlet Shut Off Valve
11.	Outlet Shut Off Valve

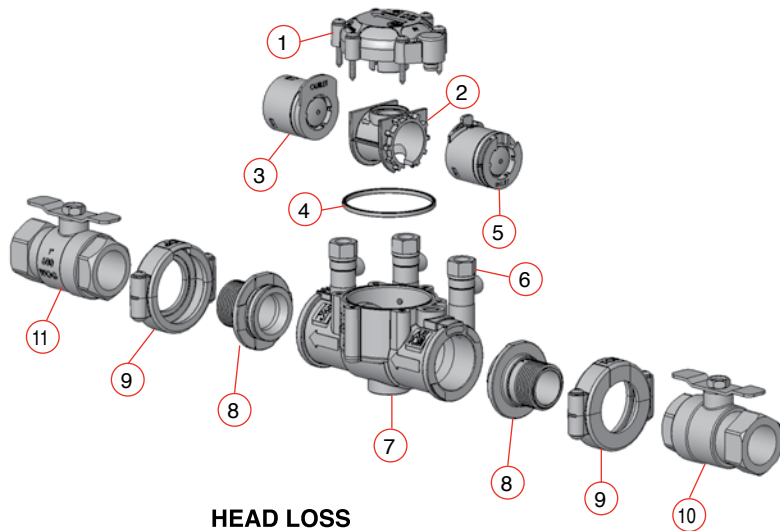

HEAD LOSS

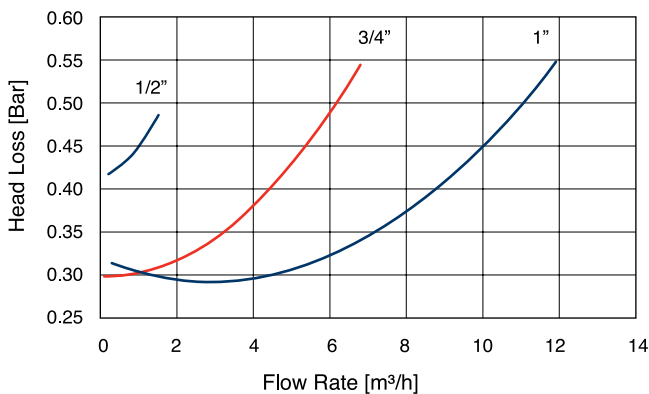

HEAD LOSS

