

MODEL 2000ss Double Check Assembly

AMES^{CO.}
FLUID CONTROL SYSTEMS

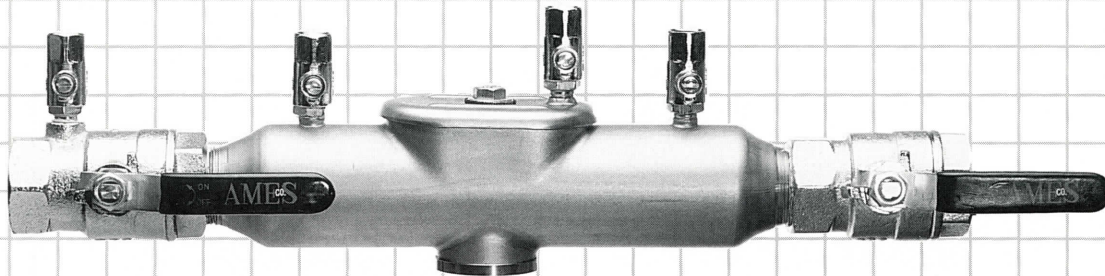

AMES SILVER BULLET: LONG LIFE 100% STAINLESS STEEL BODY

■ Application

The Ames 2000ss provides positive drip-tight closure against the reverse flow of non potable liquids caused by a cross connection. The 2000ss can be used in fire protection systems, plumbing systems, irrigation systems and other systems requiring low and intermediate hazard protection.

■ Operation

In normal flow conditions the independently operating cartridge checks remain closed until there is a demand for water. Each of the cartridge checks in series is designed to open at approximately (1) PSI pressure differential in the direction of flow. At cessation of flow or under a back pressure condition, both cartridge checks will close until the resumption of normal flow.

■ Installation

The 2000ss should be installed with adequate clearance and easy accessibility for maintenance and testing. The 2000ss may be installed vertically or horizontally. Refer to local codes for specific installation requirements.

■ Features

- Non-corrosive 300 series stainless steel body construction.
- Single bolt O-ring seated stainless steel access cover for easy servicing.
- Cartridge check assembly for long term reliability and ease of serviceability.
- Simple service procedures, requires no special tools.
- Temperature rated to 110° F.
- 175 PSI rated working pressure.
- Assembly ASSE 1015 approved.
- Horizontal or vertical installation.
- Wye strainer optional.
- Straight through flow-way.
- Documented low pressure loss.

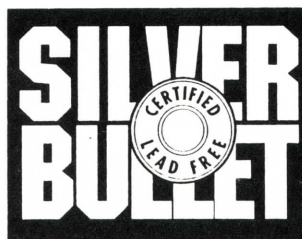

MODEL 2000ss Double Check Assembly

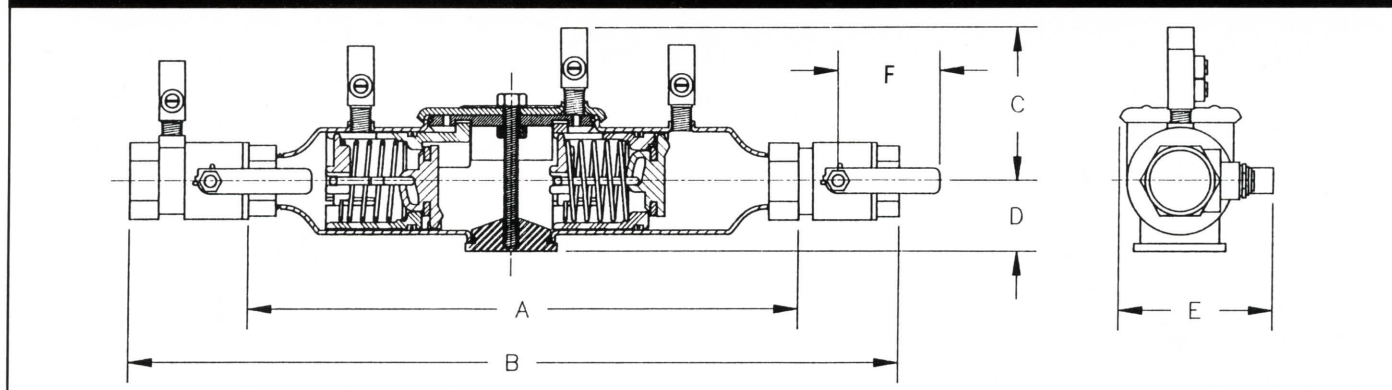

Ames 2000ss - Weights & Dimensions (inches)

SIZE	A	B	C	D	E	F	Net Wt. (lb.) w/Gates	Net Wt. (lb.) w/o Gates
3/4"	10 3/4"	16"	3"	1 1/2"	3 3/4"	4"	4.75#	3#
1"	10 3/4"	16"	3"	1 1/2"	4"	4 1/2"	5.75#	3#
1 1/4"	10 3/4"	16"	3"	1 1/2"	4 1/2"	4 3/4"	7#	3#
1 1/2"	15"	23 1/4"	4"	2 1/2"	5 1/2"	6 1/2"	20#	14#
2"	15"	23 1/4"	4"	2 1/2"	5 3/4"	6 1/2"	25#	14#

Physical Characteristics

Sizes - 3/4", 1", 1 1/4", 1 1/2", 2"
 Rated working pressure - 175 psi
 Temperature range - 32°F - 110°F
 All internal metal parts 300 series stainless steel
 Construction 300 series stainless steel construction
 Assembly shall be ASSE 1015 approved

Specifications

The double check shall consist of two independently operated spring loaded cartridge checks, required test cocks, and inlet and outlet resilient seat ball valves. Each cartridge check shall be internally loaded and provide a positive drip tight closure against the reverse flow of liquid caused by back siphonage or back pressure. The modular cartridge check includes a stainless steel spring and swing poppet, rubber faced disc and a replaceable seat. The body shall be manufactured from 300 series stainless steel, 100% lead free through the waterway, with a single bolt access cover. No special tools shall be required for servicing. Double check shall be Ames 2000ss.

3/4" Documented Flow Characteristics (Including shut-off valves)

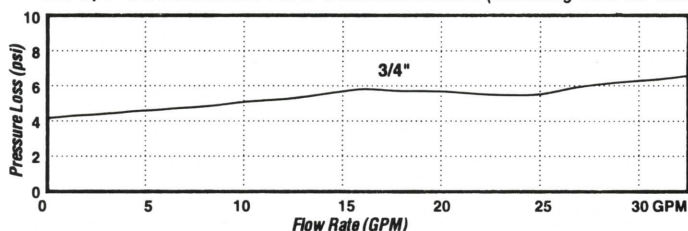

1 1/2" Documented Flow Characteristics (Including shut-off valves)

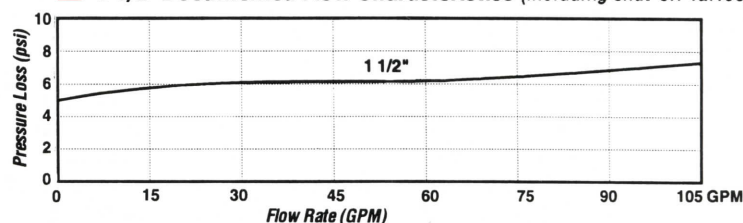

1" Documented Flow Characteristics (Including shut-off valves)

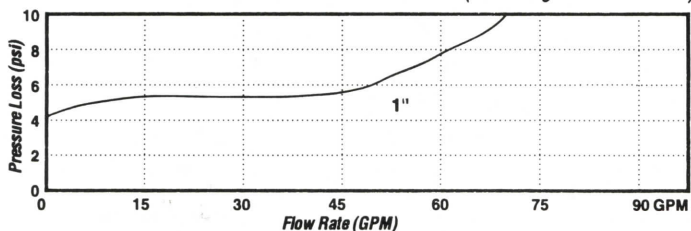

2" Documented Flow Characteristics (Including shut-off valves)

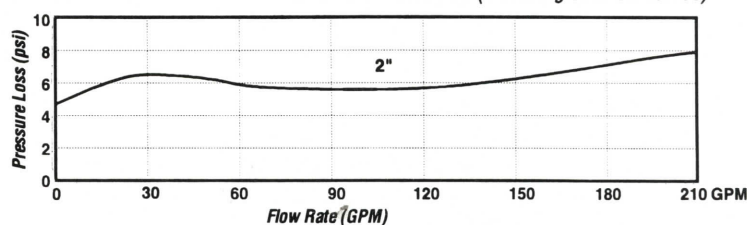

1 1/4" Documented Flow Characteristics (Including shut-off valves)

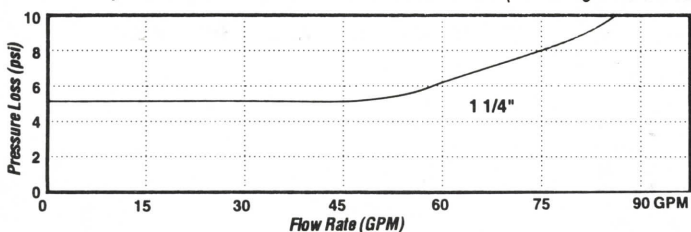

Contact the factory for specific approvals

AMES^{CO.}
 FLUID CONTROL SYSTEMS