

# MasterSeries® 876VST

## Double Check Detector Backflow Prevention Assembly

Size: 2½" - 10"

The FEBCO MasterSeries 876VST Double Check Detector Assembly is specifically designed to protect against possible backpressure and backsiphonage conditions for non-health hazard (i.e., pollutant) application in accordance with Local Governing Water Utility Code.

This Backflow Assembly is primarily used on potable drinking water systems and fire sprinkler systems, where Local Governing Code mandates protection from non-potable quality water being pumped or siphoned back into the potable water system.



MODEL 876VST DOUBLE CHECK DETECTOR ASSEMBLY

### Features

#### Main Valve:

- Inline Serviceable Assembly
- Horizontal "N-Pattern" Installations
- Vertical-Up "Z-Pattern" Installations
- No Special Tools Required for Servicing
- Captured Modular Spring Assembly
- Reversible & Replaceable Discs
- Field Replaceable Seats
- Ductile Iron Valve Body Design
- Stainless Steel Check Components
- Winterization feature with disc retainers and valve body drain ports
- Clapper Check Assembly
- Commonality between 1st & 2nd Check Components
- Captured O-ring Design

#### Auxiliary Bypass:

- Compact Bypass Design; Remains within Main Valve Assembly Profile
- Inline Serviceable ¾" Backflow Assembly
- No Special Tools Required for Servicing
- Field Replaceable Seats & Discs
- Detect Potential Underground Water Leaks
- Detect Unauthorized Water Usage

### Specifications

The FEBCO MasterSeries 876VST Double Check Detector Valve Assembly shall be installed on the potable water supply and at each point of cross-connection to protect against possible backpressure and backsiphonage conditions for non-health hazard (i.e., pollutant) applications. The assembly shall consist of a main line valve body composed of two (2) independently acting approved clapper style check modules with replaceable seats and disc rubbers. Servicing of both check modules does not require any special tools and are accessed through independent top entry covers. This assembly shall be fitted with approved UL/FM inlet/outlet resilient seated shutoff valves and contain four (4) properly located resilient seated test cocks as specified by AWWA Standard C510. The auxiliary bypass line contains a 5/8" x 3/4" Water Meter that complies with ANSI/AWWA Standard C700 coupled with an approved double check assembly (DC) compliant to AWWA Standard C510. The bypass line is designed to detect leaks or unauthorized water usage of the water system while protecting against possible backpressure and backsiphonage conditions for non-health hazard (i.e., pollutant) application. The assembly shall be approved for horizontal and/or vertical-up installations while meeting the requirements of AWWA Standard C510 flow and pressure loss performance parameters.

#### NOTICE

The information contained herein is not intended to replace the full product installation and safety information available or the experience of a trained product installer. You are required to thoroughly read all installation instructions and product safety information before beginning the installation of this product.

#### WARNING

It is illegal to use this product in any plumbing system providing water for human consumption, such as drinking or dishwashing, in the United States. Before installing standard material product, consult your local water authority, building and plumbing codes.

Job Name \_\_\_\_\_

Contractor \_\_\_\_\_

Job Location \_\_\_\_\_

Approval \_\_\_\_\_

Engineer \_\_\_\_\_

Contractor's P.O. No. \_\_\_\_\_

Approval \_\_\_\_\_

Representative \_\_\_\_\_

FEBCO product specifications in U.S. customary units and metric are approximate and are provided for reference only. For precise measurements, please contact FEBCO. FEBCO reserves the right to change or modify product design, construction, specifications, or materials without prior notice and without incurring any obligation to make such changes and modifications on FEBCO products previously or subsequently sold.

## Options - Suffix

OSY: UL/FM Approved OS&Y Gate Valves [ANSI/AWWA C515 Compliant]

CFM: Totalizing Cubic feet/min  $\frac{5}{8}$ " x  $\frac{3}{4}$ " Water Meter [ANSI/AWWA C700 Compliant]

GPM: Totalizing Gallons/min  $\frac{5}{8}$ " x  $\frac{3}{4}$ " Water Meter [ANSI/AWWA C700 Compliant]

LG: Less Shutoff valves; This is NOT an APPROVED ASSEMBLY

### Example Ordering Description:

4" 876VST-OSY-GPM - Valve Assembly fitted with OS&Y Shutoff Valves & Gallons per Minute Water Meter

4" 876VST-OSY-CFM - Valve Assembly fitted with OS&Y Shutoff Valves & Cubic Feet per Minute Water Meter

### Available Components

**Wye Strainer:** FDA Approved [ASME B16.1 Class 125 & AWWA Class D Flange]

**Series 611 Valve Setter:** MJ x MJ - Mechanical Joint x Mechanical Joint [AWWA C111/A21.11]

MJ x FL - Mechanical Joint x Flange [AWWA C111/A21.11; ASME B16.1 Class 125/ AWWA Class D Flange]

FL x FL - Flange x Flange [ASME B16.1 Class 125 & AWWA Class D Flange]

## Materials

Below is a general materials list of the Model 876VST. All assemblies size 2½" through 10" is similar in materials and construction. Please contact your local FEBCO Representative if you require further information.

Main Valve Body: Ductile iron Grade 65-45-12

Coating: Fusion epoxy coated internal and external AWWA C550-90

Shutoff Valves: OSY resilient wedge gate valve AWWA C515 (UL/FM)

Check Seats: Stainless Steel

Disc Holder: Stainless Steel

Elastomer Disc: Silicone

Spring: Stainless Steel

Clamp: AWWA C606

## Approvals – Standards:

- Approved by the Foundation for Cross-Connection Control and Hydraulic Research at The University of Southern California [FCCCHR-USC]
- ASSE 1048 Listed
- \*\*UL Classified [US & Canada]
- \*\*FM Approved
- IAPMO/cUPC
- AWWA Standard C510 Compliant
- End Connections: Compliant to ASME B16.1 Class 125 & AWWA Class D Flange

\*\*Assembly configured with UL/FM Approved OS&Y RW Gate Valves. Less gate valve assemblies are not UL/FM approved configurations.

## Assembly Flow Orientation:

Horizontal (N-Pattern 2½" – 8") - Approved by FCCCHR-USC, ASSE, cULus, FM, IAPMO/cUPC

Vertical Up (Z-Pattern 2½" – 8") - Approved by FCCCHR-USC, ASSE, cULus, FM, IAPMO/cUPC



## Pressure - Temperature

Max. Working Pressure: 175psi (12.1 bar)

Min. Working Pressure: 10psi (0.7 bar)

Hydrostatic Test Pressure: 350psi (24.1 bar)

Hydrostatic Safety Pressure: 700psi (48.3 bar)

Temperature Range: 33°F - 140°F [0.5°C- 60°C] Continuous

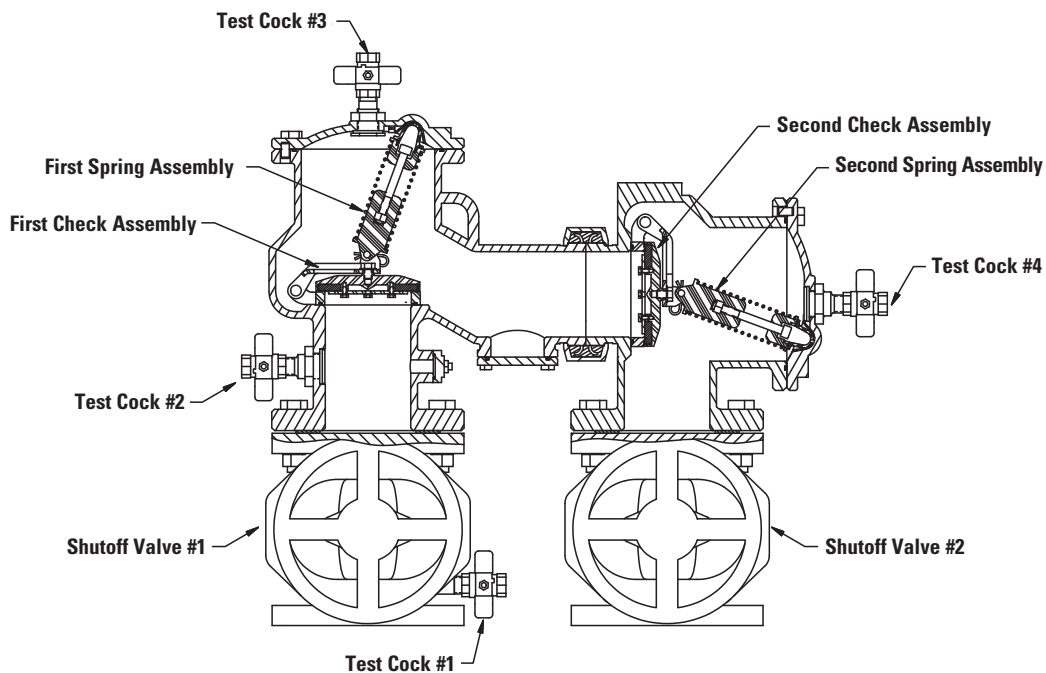

## Dimensions – Weights

**Size: 2½" - 10"**

Below are the nominal dimensions and physical weights for the Model 876VST size 2½" through 10". Allowances must be made for normal manufacturing tolerances. Please visit our website to download a copy of this product's installation instructions, or contact your local FEBCO Representative for more information.

### Model 876VST Standard Orientation (N-Pattern)

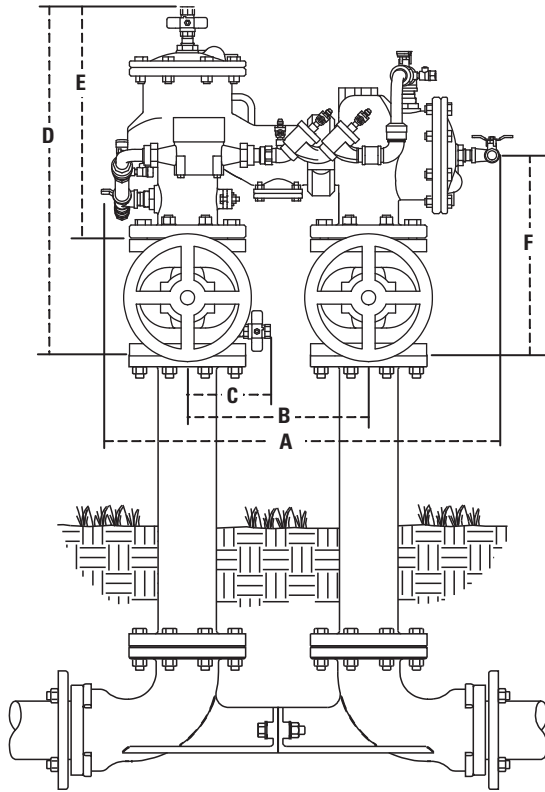

**Note:** The Series 876VST is shipped in the standard (N-Pattern) orientation as shown above.

### Model 876VST Vertical Orientation (Z-Pattern)

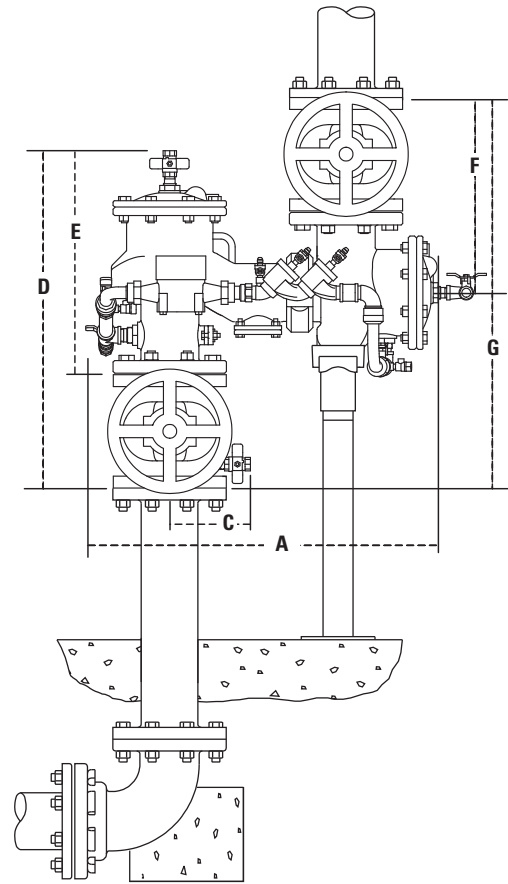

### Gate Valve Side View Clearance

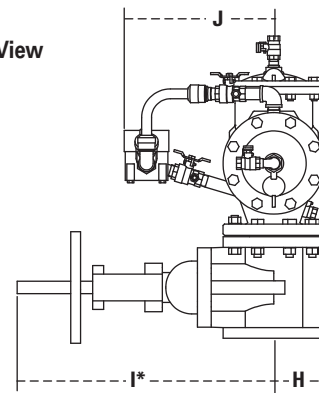

### 876VST

SIZE	DIMENSIONS																		WEIGHT**			
	A		B		C		D		E		F		G		H		I*		J		OSY	
in.	in.	mm	in.	mm	in.	mm	in.	mm	in.	mm	in.	mm	in.	mm	in.	mm	in.	mm	in.	mm	lbs.	kg.
2½	25¾	654	12½	318	6¼	159	24¼	616	16%	422	13¾	346	27¼	692	3½	89	16%	416	11½	292	216	98
3	25¾	654	12½	318	6¼	159	24¼	629	16%	422	14¾	359	28¼	718	3¾	95	22¼	565	11½	292	242	110
4	27¾	708	14	356	7	178	26¾	680	17¼	451	15½	394	31	787	4½	114	23¼	591	13	330	347	157
6	32¼	819	16	406	8	203	32¼	819	21%	548	18%	473	37¼	946	5½	140	30%	765	13	330	529	240
8	37½	953	18½	470	9¼	235	36%	324	24%	632	20¾	527	41½	1054	6¾	172	37¼	959	14½	368	827	375
10	42½	1080	21	533	10	254	40%	1035	27½	699	24	610	48	1219	8	203	48	1219	15	381	1335	605

Notes:

\* Indicates nominal dimensions with OSY Gate Valves (Full Open Position)

\*\* Indicates weight of complete Backflow Assemblies with specified Gate Valves

# Performance

Flow capacity chart identifies valve performance based upon rated water Velocity up to 20fps

- Maximum service flow rate is determined by maximum rated Velocity of 7.5fps.
- AWWA Manual M-22 (Appendix C) recommends that the maximum water Velocity in the services be not more than 10fps.
- UL flow rate is determined by typically rated Velocity of 15 feet/sec.

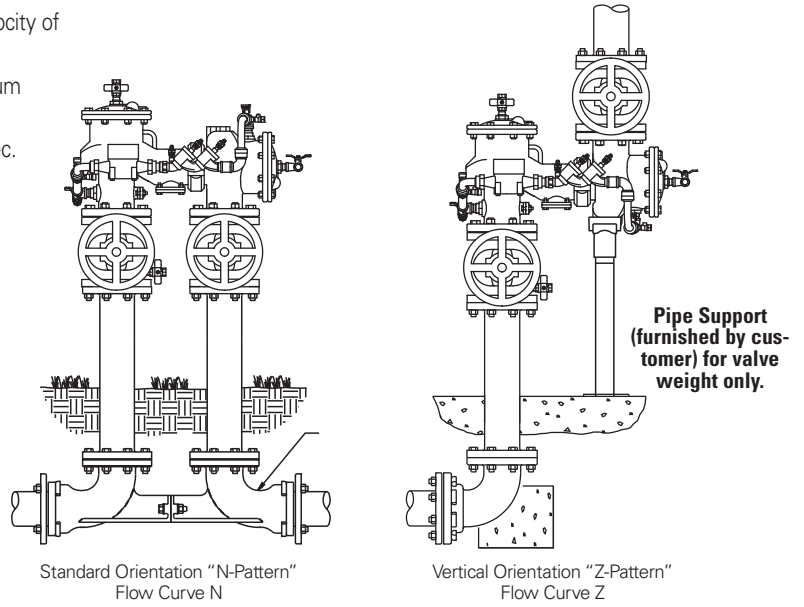

# Capacity

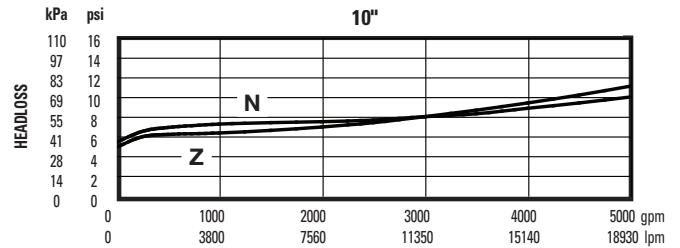
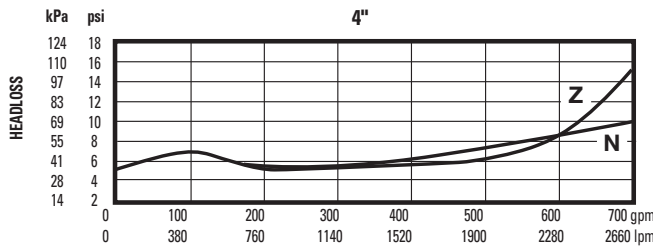
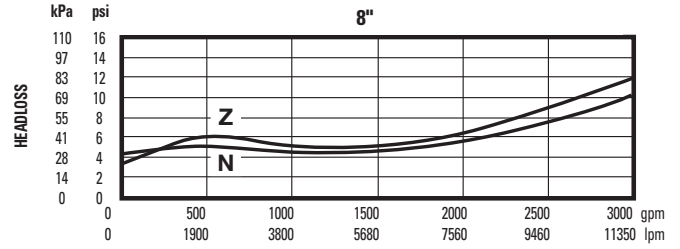
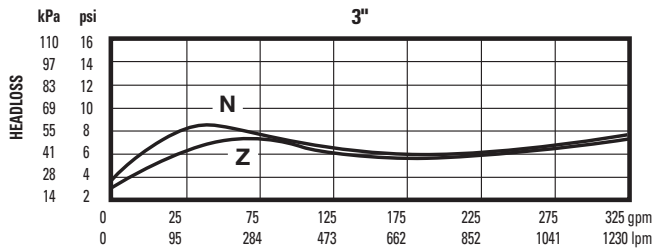
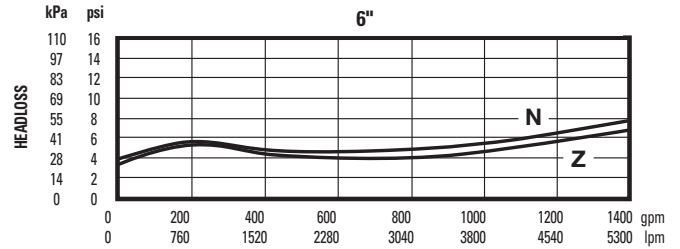
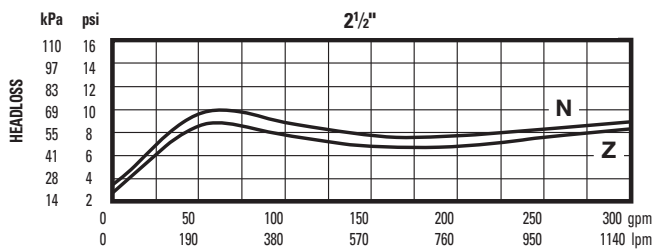

The 6" and 10" flow curves (N-standard orientation) include the FEBCO Valve Setter Series 611.



A Watts Water Technologies Company



USA: Tel: (800) 767-1234 • Fax: (800) 788-4491 • FEBCOonline.com  
 Canada: Tel: (905) 332-4090 • Fax: (905) 332-7068 • FEBCOonline.com  
 Latin America: (52) 81-1001-8600 • Fax: (52) 81-8000-7091 • FEBCOonline.com