

For Health Hazard Applications

Job Name _____

Contractor _____

Job Location _____

Approval _____

Engineer _____

Contractor's P.O. No. _____

Approval _____

Representative _____

Series 909

Reduced Pressure Zone Assemblies

909 Sizes: 3/4", 1" (20, 25mm)
909M1 Sizes: 1 1/4", 1 1/2", 2" (32, 40, 50mm)

Series 909 Reduced Pressure Zone Assemblies are designed to provide superior cross-connection control protection of the potable water supply in accordance with national plumbing codes and containment control for water authority requirements. This series can be utilized in a variety of installations, including health hazard cross-connections in plumbing systems or for containment at the service line entrance. With its exclusive design incorporating the "air-in/water-out" principle it provides maximum relief valve discharge during the emergency conditions of combined backsiphonage and backpressure with both checks fouled. Model 909QT, standardly furnished with full port, resilient seated and bronze ball valve shutoffs. Sizes 3/4" and 1" (20 and 25mm) shutoffs have tee handles.

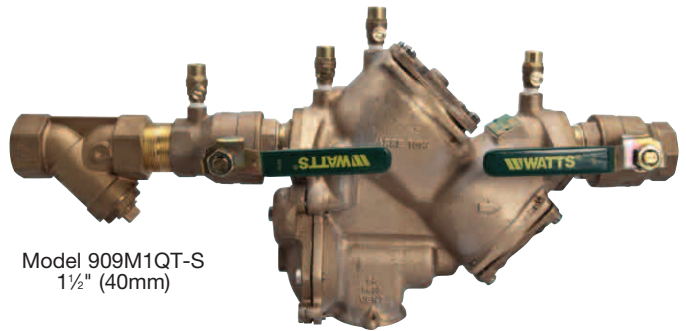

Model 909M1QT-S
1 1/2" (40mm)

Features

- Modular design
- Replaceable seats
- Compact for installation ease
- Horizontal or vertical (up or down) installation
- No special tools required for servicing

Specifications

A Reduced Pressure Zone Assembly shall be installed at each cross-connection to prevent backsiphonage and backpressure of hazardous materials into the potable water supply. The assembly shall consist of a pressure differential relief valve located in a zone between two positive seating check valves. Backsiphonage protection shall include provision to admit air directly into the reduced pressure zone via a separate channel from the water discharge channel, or directly into the supply pipe via a separate vent. The assembly shall include two tightly closing shutoff valves before and after the assembly, test cocks and a protective strainer upstream of the No. 1 shutoff valve. The assembly (specify Model 909 for temperatures up to 140°F (60°C) or Model 909HW for temperatures up to 210°F (99°C)) shall meet the requirements of ASSE Std. 1013; AWWA Std. C-511-92 CSA B64.4; FCCCHR of USC Manual Section 10. Listed by IAPMO (UPC). SBCCI (Standard Plumbing code). The assembly shall be a Watts Regulator Company Series 909QTS or 909QTSHW.

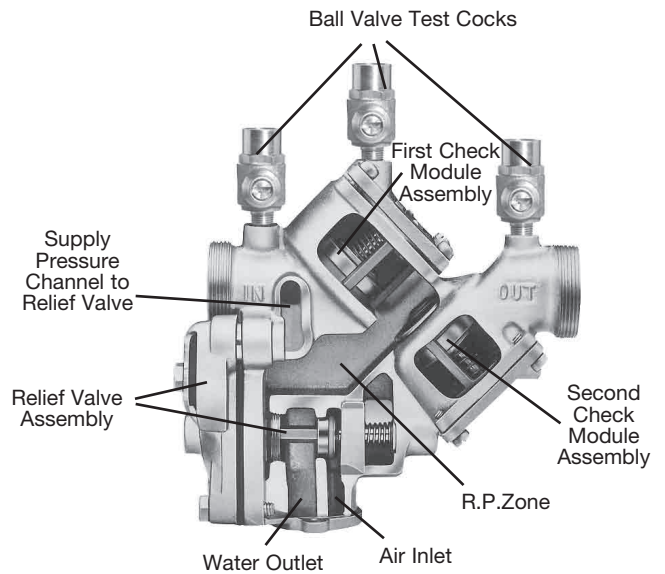

Now Available
WattsBox Insulated Enclosures.
 For more information, send for literature ES-WB.

Watts product specifications in U.S. customary units and metric are approximate and are provided for reference only. For precise measurements, please contact Watts Technical Service. Watts reserves the right to change or modify product design, construction, specifications, or materials without prior notice and without incurring any obligation to make such changes and modifications on Watts products previously or subsequently sold.



Models

Suffix

C&T	Cap and tether test cocks
PC	Internal polymer coating
QT	Quarter-turn ball valves
S	Bronze strainer
HW	Stainless steel check modules for hot and harsh water conditions
LF	Without shutoff valves
HC	Inlet/outlet fire hydrant fitting (2" only)

Prefix

C	Clean and check strainer - ¾" and 1" (20 and 25mm) only
U	Union - ¾" and 1" (20 and 25mm) only
FAE	Flanged adapter ends - 1¼", 1½", 2" (32, 40, 50mm) only

NOTE: The installation of a drain line is recommended. When installing a drain line, an air gap is necessary.

Materials

Body:	Bronze
Check Seats:	909 Celcon®
Relief Valve Seats:	Stainless steel 909HW
Test Cocks:	Bronze

Celcon® is a registered trademark of Celanese, Limited

Connections

¾" – 1" (19 – 25mm) 909-NPT Female threaded body connection

1¼" – 2" (32 – 50mm) 909-M1-NPT Male threaded body connection

Standards

AWWA C-511-92

FCCCHR of USC Manual Section 10

IAPMO (UPC), SBCCI (Standard Plumbing code)

Approvals

Listed by IAPMO

Listed by SBCCI



*Approved by the Foundation for Cross-Connection Control and Hydraulic Research at the University of Southern California.

Horizontal and vertical "flow-up" approval on ¾" (20mm) and 1" (25mm) sizes (models 909QT, 909PCQT, and U909QT).

Pressure – Temperature

Temperature Range: 33°F – 140°F (0.5°C – 60°C) continuous, 180°F (82°C) intermittent

Maximum Working Pressure: 175psi (12.1 bar)

Series 909HW:

Temperature Range: 33°F – 210°F (0.5°C – 99°C)

Maximum Working Pressure: 175psi (12.1 bar)

How it Operates

The unique relief valve construction incorporates two channels: one for air, one for water. When the relief valve opens, as in the accompanying air-in/water-out diagram, the right-hand channel admits air to the top of the reduced pressure zone, relieving the zone vacuum. The channel on the left then drains the zone to atmosphere. Therefore, if both check valves foul, and simultaneous negative supply and positive backpressure develop, the relief valve uses the air-in/water-out principle to stop potential backflow.

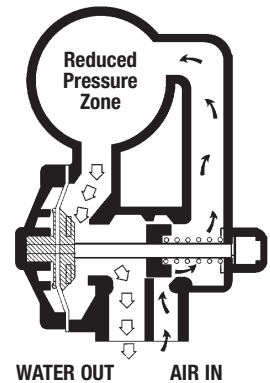

Dimensions – Weights

When installing a drain line use 909AG series Air Gaps on Series 909 backflow preventers. *909EL series elbows are for air gaps on backflow preventers in vertical installations.

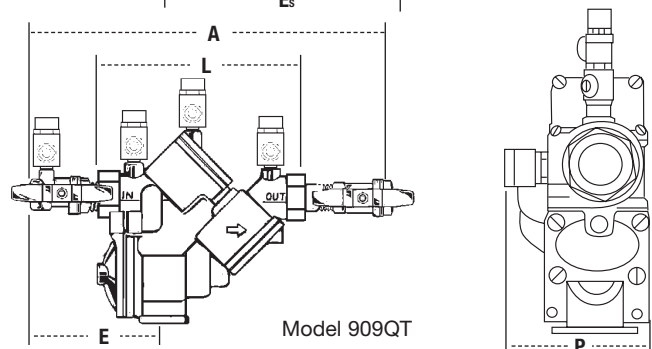
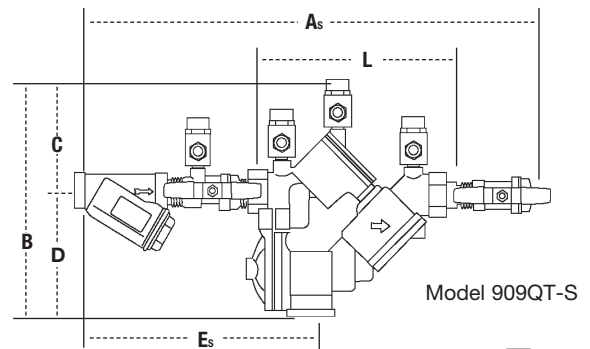
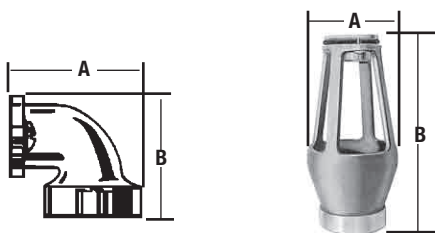

		909 DRAIN		OUTLET		DIMENSIONS				WEIGHTS	
Iron Body No.	Desc.	Sizes		Sizes		A		B		lbs.	kg.
		in.	mm	in.	mm	in.	mm	in.	mm		
909-AG-C	Air Gap	¾, 1	19, 25	1	25	¾	83	4 7/8	124	1 ½	0.7
909-EL-C	Elbow*	¾, 1	19, 25	–	–	2 ¾	60	2 ¾	60	¾	0.2
909-AG-F	Air Gap	1 ¼-2	32-50	2	50	4 ¾	111	6 ¾	171	3 ¼	1.5
909-EL-F	Elbow*	1 ¼-2	32-50	–	–	3 ¾	92	3 ¾	92	2	0.9

Capacity

As compiled from documented Foundation for Cross-Connection Control and Hydraulic Research of the University of Southern California lab tests.
 *Typical maximum system flow rate (7.5 feet/sec.)

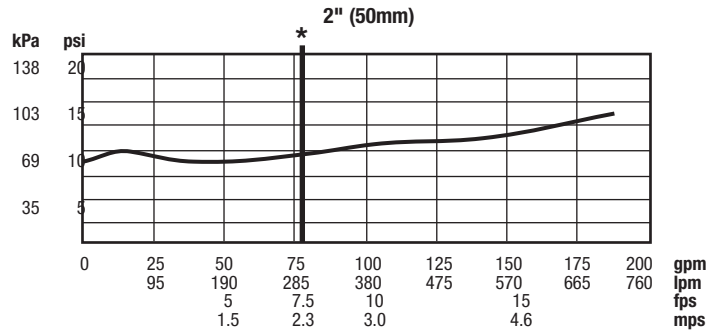
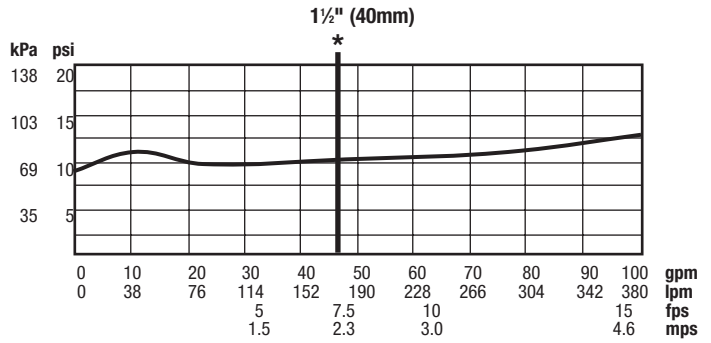
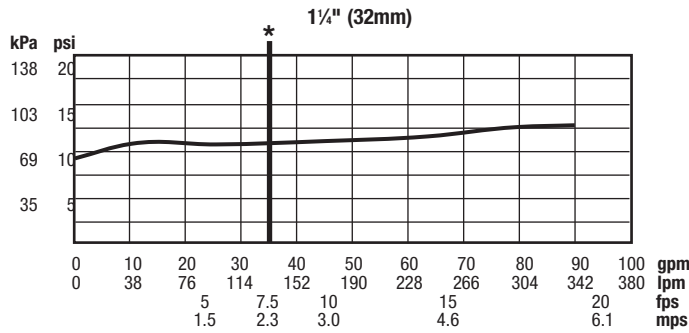
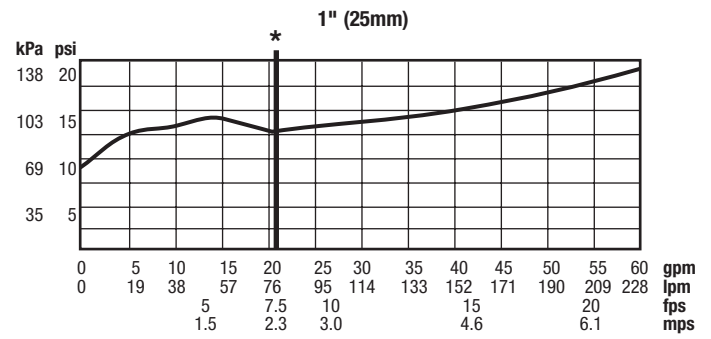
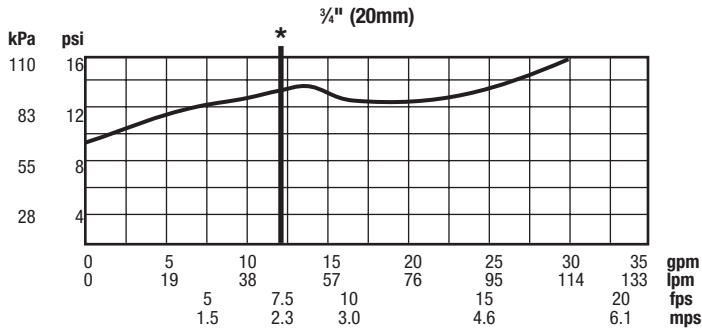

Suffix HC - Fire Hydrant Fittings dimension "A" = 23 3/4" (603mm)

SIZE (DN)	DIMENSIONS										WEIGHT											
	A		As		B		C		D		E		Es		L		P		QT		QT-S	
	in.	mm	in.	mm	in.	mm	in.	mm	in.	mm	in.	mm	in.	mm	in.	mm	in.	mm	lbs.	kgs.	lbs.	kgs.
*909QT, 909QT-S Dimensions																						
3/4"	14 3/8	365	18 1/16	459	8 3/4	222	4	102	4 3/4	121	6 3/4	171	10 11/16	259	7 5/16	186	3 3/8	98	14	6.4	15.6	7.1
1"	15 1/2	391	19 3/8	498	8 3/4	222	4	102	4 3/4	121	7	178	11	279	7 5/16	186	3 3/8	98	15	6.8	17.5	7.9
1 1/4"M1	18 1/2	470	23 3/16	595	11 1/8	295	5 1/2	140	6 1/2	165	7 1/2	191	12 3/16	310	10 3/8	264	5 1/4	133	40	18.1	42.8	19.4
1 1/2"M1	19	483	24 3/8	619	11 1/8	295	5 1/2	140	6 1/2	165	7 1/2	191	12 3/8	321	10 3/8	264	5 1/4	133	40	18.1	44.0	20.0
2"M1	19 1/2	495	25 1/16	659	11 1/8	295	5 1/2	140	6 1/2	165	7 3/4	197	13 15/16	354	10 3/8	264	5 1/4	133	40	18.1	47.4	21.5
*U909QT Dimensions - with integral body unions (Prefix "U")																						
3/4"	14 3/8	371	19 1/16	484	8 3/4	222	4	102	4 3/4	121	6 3/4	171	10 11/16	259	7 5/16	186	3 3/8	98	14	6.4	15.6	7.1
1"	15 1/2	397	20 15/16	532	8 3/4	222	4	102	4 3/4	121	7	178	11	279	7 5/16	186	3 3/8	98	15	6.8	17.5	7.9
*FAE909QT - Dimensions with flanged adapter ends (Prefix "FAE")																						
1 1/4"	19	483	24 1/2	622	11 1/8	295	5 1/2	140	6 1/2	165	7 1/2	191	12 3/16	310	10 3/8	264	5 1/4	133	40	18.1	42.8	19.4
1 1/2"	19 3/4	502	26 3/8	664	11 1/8	295	5 1/2	140	6 1/2	165	7 1/2	191	12 3/8	321	10 3/8	264	5 1/4	133	40	18.1	44.0	20.0
2"	21	533	28 3/8	721	11 1/8	295	5 1/2	140	6 1/2	165	7 3/4	197	13 15/16	354	10 3/8	264	5 1/4	133	40	18.1	47.4	21.5

Subscript 'S' = strainer model

For additional information, visit our web site at: www.watts.com



A Watts Water Technologies Company

ES-909S 1320



USA: Tel: (978) 688-1811 • Fax: (978) 794-1848 • www.watts.com
Canada: Tel: (905) 332-4090 • Fax: (905) 332-7068 • www.watts.ca

© 2013 Watts