

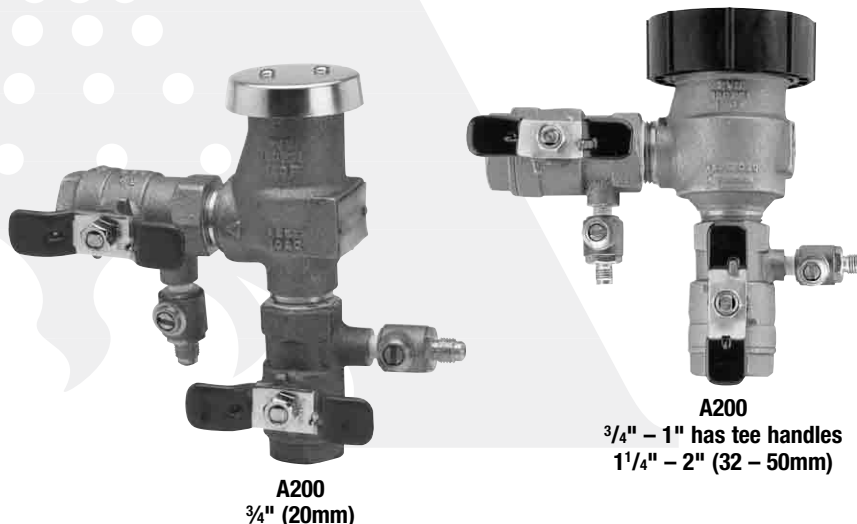

Series A200

Pressure Vacuum Breakers

Sizes: 3/4" - 2" (20 - 50mm)
 1 1/4" contact factory



Features

- Replaceable plastic seat
- Easy maintenance of internal parts
- Acetal bonnet acts as "freeze plug" to prevent body damage
- O-ring bonnet seal for less possibility of fouling
- Silicone seat disc for durability
- Test cocks positioned for easy testing and winterization
- Compact space saving design
- Standardly equipped with tee handle quarter turn ball valve shutoffs 3/4" - 1" (20-25mm). The 1 1/4" - 2" (32-50mm) feature lever handles
- No special tools required for servicing
- Bronze body for durability

Series A200 Pressure Vacuum Breakers are designed to prevent back-siphonage of contaminated water into a potable water supply. The valve is ideal for irrigation systems, industrial process water systems and other continuous pressure piping system applications where the water enters the equipment at or below its flood rim. The disc float and check valve are suitable for temperatures up to 140°F (60°C). The resilient seating float O-ring and seal check disc are silicone rubber which is resistant to heat, shock and chemical attack.

Specifications

A pressure vacuum breaker shall be installed where indicated on the plans to prevent the backsiphonage of contaminated water. This assembly is not to be used where there is a possibility that a backpressure condition may develop. The assembly will incorporate an acetal bonnet with silicone rubber O-ring seal and silicone rubber seat disc. The valve shall have replaceable seats. Check assembly shall be guided over its full stroke by 'V' notched guides. The assembly shall meet the requirements of ANSI/ASSE Standard 1020. The valve should be an Ames Company Series A200.

Job Name _____ Contractor _____

Job Location _____ Approval _____

Engineer _____ Contractor's P.O. No. _____

Approval _____ Representative _____

Ames product specifications in U.S. customary units and metric are approximate and are provided for reference only. For precise measurements, please contact Ames Technical Service. Ames reserves the right to change or modify product design, construction, specifications, or materials without prior notice and without incurring any obligation to make such changes and modifications on Ames products previously or subsequently sold.

Materials

Springs: Stainless Steel

Bonnet: Celcon®

Vent Disc: Silicone Rubber

Disc Holder Float: Polypropylene

Check Valve Disc: Silicone Rubber

Check Valve Seat: Noryl® Plastic

Body: Bronze

Standards

ANSI, ASSE 1020, CSA B64.12, IAPMO,

USC Manual Section 10

Approvals

ANSI, ASSE, CSA, IAPMO

Approved by the foundation for Cross-Connection Control and Hydraulic Research at the University of Southern California, Manual Section 10.



Pressure — Temperature

Working Temperature: 33°F – 140° (5°C – 60°C)

Maximum Pressure: 150psi (10.3 bar)

IMPORTANT: Inquire with governing authorities for local installation requirements.

Dimensions — Weights

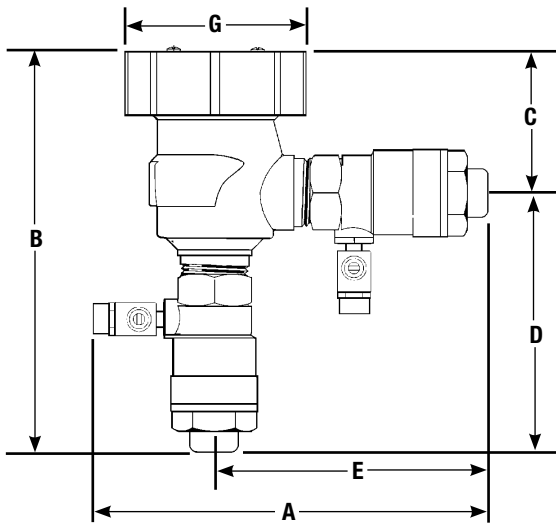

SIZE (DN)		DIMENSIONS										WEIGHT			
in.	mm	A		B		C		D		E		G		lbs.	kg.
3/4	20	6 1/2	165	6 1/2	165	2 1/16	65	3 15/16	100	4 1/8	105	2 1/4	57	4	1.8
1	25	7 1/2	191	7 1/2	191	2 3/4	70	4 3/4	121	4 7/8	124	3 7/16	87	6	2.7
1 1/2	40	9 1/4	235	9 1/2	241	3 1/4	83	6 1/4	159	6 3/8	162	5	127	14	6.3
2	50	10 5/8	270	9 5/8	245	3 1/4	83	6 3/8	162	7	178	5	127	19	8.6

Celcon® is a registered trademark of Celanese, Limited.

Noryl® is a registered trademark of SABIC Innovative Plastics™.

Installations

This valve is designed for installation in a continuous pressure potable water supply system 12" (305mm) above the highest point of the downstream piping. The valve must be installed with the supply connected to the bottom and in a vertical position. Allow adequate space for periodic inspection, servicing or testing. The valve should not be installed in an area where freezing or spillage will cause damage. Adequate drainage/freeze protection must be provided in cold weather applications. 1.5 psi (10.34 kPa) must be exerted against the float spring to seal the float and air inlet. Do not undersize supply and discharge piping.

Important Note: Vacuum breakers are not designed, tested or approved to protect against backpressure backflow or water hammer shock. For protection against backpressure backflow, install Ames 4000B Reduced Pressure Zone Assemblies.

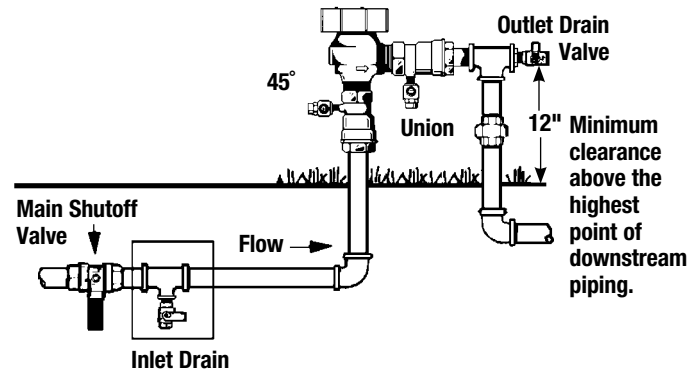

Freeze Protection Guidelines

1. Close main shutoff valve.
2. Open upstream drain, test cocks and isolation ball valves to depressurize line.
3. Purge with air.
4. Leave test cocks and isolation ball valve handles in 45° angle to drain ball valves and prevent casting damage.

Installations

As compiled from documented Foundation for Cross-Connection Control and Hydraulic Research at the University of Southern California lab tests.

*Typical maximum flow rate (7.5 feet/sec.)

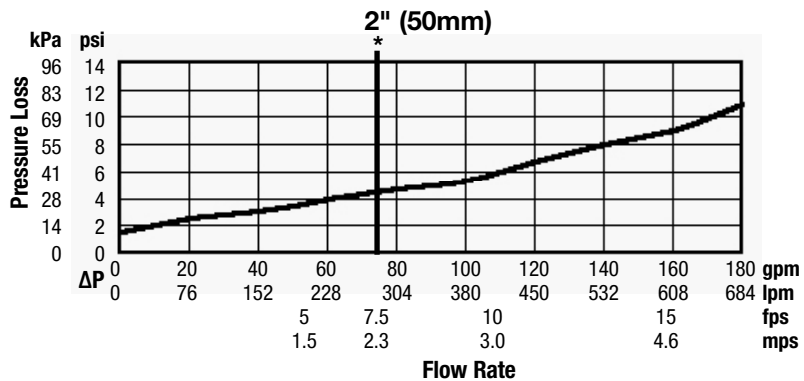
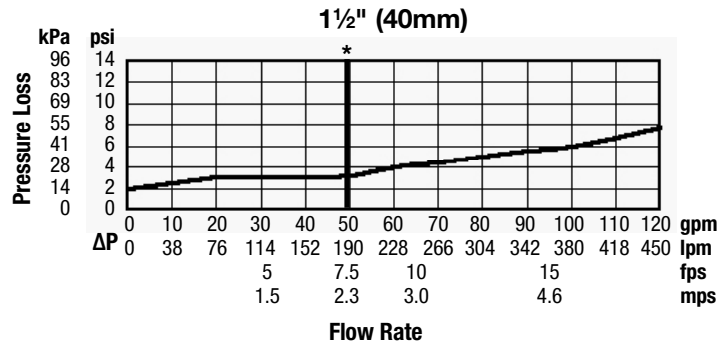
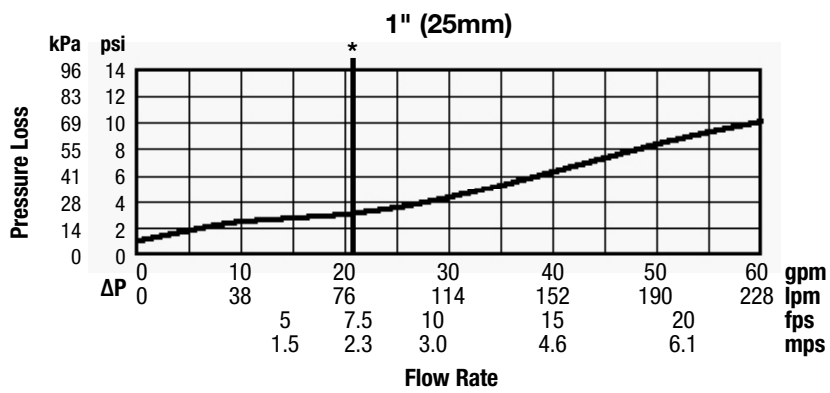
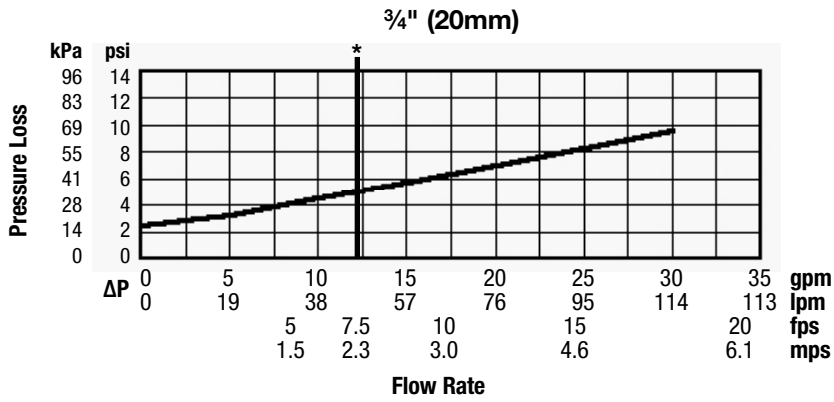

For additional information, visit our web site at: www.amesfirewater.com



www.amesfirewater.com



A Watts Water Technologies Company

USA: Backflow- Sacramento, CA • Tel: (916) 928-0123 • Fax: (916) 928-9333

Control Valves- Houston, TX • Tel: (713) 943-0688 • Fax: (713) 944-9445

Canada: Burlington, ON • Tel: (905) 332-4090 • Fax: (905) 332-7068

ES-A-A200 0513

© 2011 Ames Fire & Waterworks