



**FEATURES:**

**Sizes:** □ 3/4" □ 1"

Max. working pressure: 150 PSI (1200 kPa)  
 Max. working temperature: 140°F (60°C)  
 Hydrostatic Test Pressure: 300 PSI (2400 kPa)

**MATERIALS:**

Valve Body: Bronze (ASTM B584)  
 Access Cover: ABS  
 Polymers: Noryl™, NSF Listed  
 Elastomers: Silicone / Buna-n  
 Springs: Stainless Steel

**OPTIONS:**

- B9510 or B9511 – less ball valves
- U – with union end ball valves

**STANDARDS COMPLIANCE:**

ASSE® Listed 1020

Approved by the Foundation for Cross-Connection Control and Hydraulic Research at the University of Southern California

**FLOMATIC SPECIFICATIONS:**

Designed for installation on potable water lines to prevent against contaminated water backsiphonage into the potable water supply. Assembly shall provide protection against backsiphonage where a potential health hazard exist.

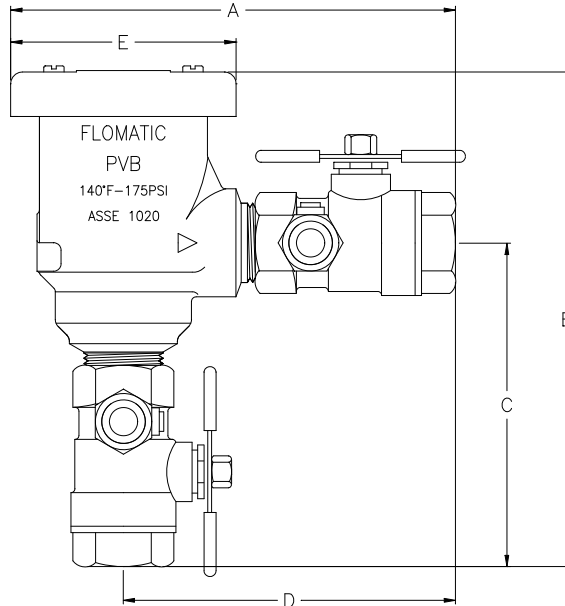

Size		Part #	A		B		C		D		E		Width		Wgt w/ BV		Wgt no BV	
Inch	mm		Inch	mm	Inch	mm	Inch	mm	Inch	mm	Inch	mm	Inch	mm	lbs	kg	lbs	kg
3/4	20	B9500	6.17	157	7.09	180	4.44	113	4.67	119	3	76	3.86	98	3.4	1.5	1.7	.8
1	25	B9501	6.52	166	7.55	192	4.94	125	5.02	128	3	76	4	102	4	1.8	1.7	.8

**FLOW CHARACTERISTICS**

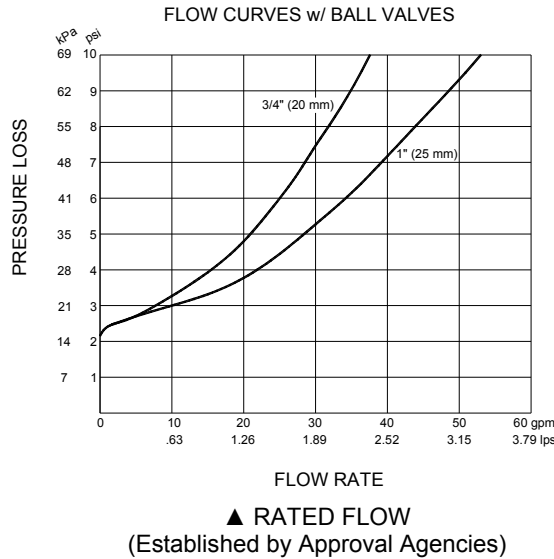

**TYPICAL INSTALLATION**

Model PVB Pressure Vacuum Breaker should be installed with adequate clearance and easy accessibility for testing and maintenance and must be protected from freezing. Local codes shall govern installation requirements. Unless otherwise specified, the installation shall be in accordance with the manufacturer's instructions and the latest edition of the Uniform Plumbing Code. The installation shall be made so that no part of the unit can be submerged. Thermal water expansion can cause excessive pressure. Excessive pressure situations should be eliminated to avoid possible damage to the system and assembly.

Capacity thru Schedule 40 Pipe (GPM)				
Pipe size	5 ft/sec	7.5 ft/sec	10 ft/sec	15 ft/sec
3/4"	8	12	17	25
1"	13	20	27	40

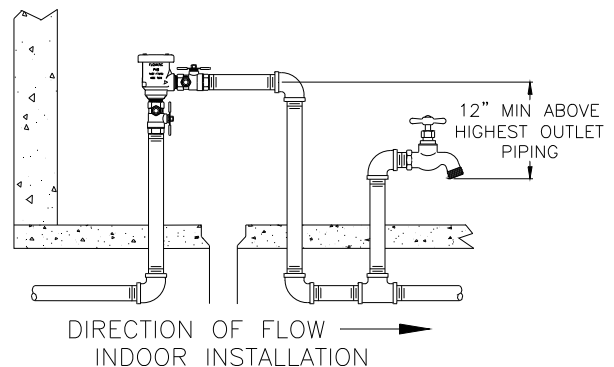
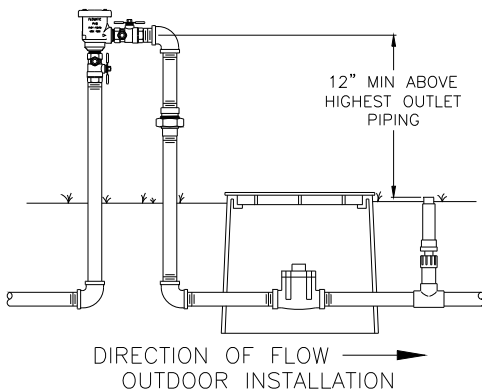

**WARRANTY:** Flomatic valves are guaranteed against defects of materials or workmanship when used for the services recommended. If in any recommended service, a defect develops due to material or workmanship, and the device is returned, freight prepaid, to Flomatic Corporation within 12 months from the date of purchase, it will be repaired or replaced free of charge. Flomatic Corporations' liability shall be limited to our agreement to repair or replace the valve only.