

LEAD FREE*

MasterSeries® LF870V

Double Check Backflow Prevention Assembly

Size: 2½" - 8" (65mm - 200mm)

The FEBCO MasterSeries LF870V Double Check Assembly is specifically designed to protect against possible backpressure and backsiphonage conditions for non-health hazard (i.e., pollutant) application in accordance with Local Governing Water Utility Code. This Backflow Assembly is primarily used on potable drinking water systems where Local Governing Code mandates protection from non-potable quality water being pumped or siphoned back into the potable water system.

The LF870V features Lead Free* construction to comply with low lead installation requirements. The Lead Free* Double Check Assembly shall comply with state codes and standards, where applicable, requiring reduced lead content.

Features

- Inline Serviceable Assembly
- Horizontal "N-Pattern" Installations
- Vertical-Up "Z-Pattern" Installations
- No Special Tools Required for Servicing
- Captured Modular Spring Assembly
- Reversible & Replaceable Discs
- Field Replaceable Seats
- Ductile Iron Valve Body Design
- Stainless Steel Check Components
- Winterization feature with disc retainers and valve body drain ports
- Clapper Check Assembly
- Commonality between 1st & 2nd Check Components
- Captured O-ring Design

MASTER series®



MODEL LF870V DOUBLE CHECK ASSEMBLY
(Shown in standard orientation)

Specifications

The FEBCO MasterSeries LF870V Double Check Valve Assembly shall be installed on the potable water supply and at each point of cross-connection to protect against possible backpressure and backsiphonage conditions for non-health hazard (i.e., pollutant) applications. The assembly shall consist of a main line valve body composed of two (2) independently acting approved clapper style check modules with replaceable seats and disc rubbers. Servicing of both check modules does not require any special tools and are accessed through independently top entry covers. This assembly shall be fitted with AWWA Compliant inlet/outlet resilient seated shutoff valves; when used on a Fire-Sprinkler application, the assembly shall be fitted with approved UL/FM inlet/outlet resilient seated shutoff valves and contain four (4) properly located resilient seated test cocks as specified by AWWA Standard C510. The assembly shall be approved for horizontal and/or vertical-up installations while meeting the requirements of AWWA Standard C510 flow and pressure loss performance parameters.

NOTICE

Inquire with governing authorities for local installation requirements

WARNING

It is illegal to use this product in any plumbing system providing water for human consumption, such as drinking or dishwashing, in the United States. Before installing standard material product, consult your local water authority, building and plumbing codes.

*The wetted surface of this product contacted by consumable water contains less than 0.25% of lead by weight.

Job Name _____	Contractor _____
Job Location _____	Approval _____
Engineer _____	Contractor's P.O. No. _____
Approval _____	Representative _____

FEBCO product specifications in U.S. customary units and metric are approximate and are provided for reference only. For precise measurements, please contact FEBCO. FEBCO reserves the right to change or modify product design, construction, specifications, or materials without prior notice and without incurring any obligation to make such changes and modifications on FEBCO products previously or subsequently sold.

Options - Suffix

OSY: UL/FM Approved OS&Y Gate Valves [ANSI/AWWA C515 Compliant]

NRS: Non-Rising Stem Gate Valves [ANSI/AWWA C509 Compliant]

LG: Less Shut-off valves; This is NOT an APPROVED ASSEMBLY

Example Ordering Description:

4" LF870V-OSY - Valve Assembly fitted with OS&Y Shutoff Valves

Available Components

Wye Strainer: FDA Approved [ASME B16.1 Class 125 & AWWA Class D Flange]

Series 611 Valve Setter: MJ x MJ - Mechanical Joint x Mechanical Joint [AWWA C111/A21.11]

MJ x FL - Mechanical Joint x Flange [AWWA C111/A21.11; ASME B16.1 Class 125/ AWWA Class D Flange]

FL x FL - Flange x Flange [ASME B16.1 Class 125 & AWWA Class D Flange]

Assembly Flow Orientation:

Horizontal (N-Pattern 2½" – 8") - Approved by FCCCHR-USC, ASSE, cULus, FM, IAPMO

Vertical Up (Z-Pattern 2½" – 8") - Approved by FCCCHR-USC, ASSE, cULus, FM, IAPMO

Materials

Below is a general materials list of the Model LF870V. All assemblies size 2½" through 8" is similar in materials and construction. Please contact your local FEBCO Representative if you require further information.

Main Valve Body: Ductile iron Grade 65-45-12

Coating: Fusion epoxy coated internal and external AWWA C550-90

Shutoff Valves: NRS resilient wedge gate valve AWWA C509 (Standard)
OSY resilient wedge gate valve AWWA C515 (UL/FM)

Check Seats: Stainless Steel

Disc Holder: Stainless Steel

Elastomer Disc: Silicone

Spring: Stainless Steel

Clamp: AWWA C606

Approvals – Standards:

- Approved by the Foundation for Cross-Connection Control and Hydraulic Research at The University of Southern California [FCCCHR-USC]
- ASSE 1015 Listed
- **UL Classified [US & Canada]
- **FM Approved
- IAPMO
- AWWA Standard C510 Compliant
- End Connections: Compliant to ASME B16.1 Class 125 & AWWA Class D Flange

**Assembly configured with UL/FM Approved OS&Y RW Gate Valves. Less gate valve assemblies are not UL/FM approved configurations.



Pressure - Temperature

Max. Working Pressure: 175 psi (12.1 bar)

Min. Working Pressure: 10 psi (0.7 bar)

Hydrostatic Test Pressure: 350 psi (24.1 bar)

Hydrostatic Safety Pressure: 700 psi (48.3 bar)

Temperature Range: 33°F - 140°F (0.5°C- 60°C) Continuous

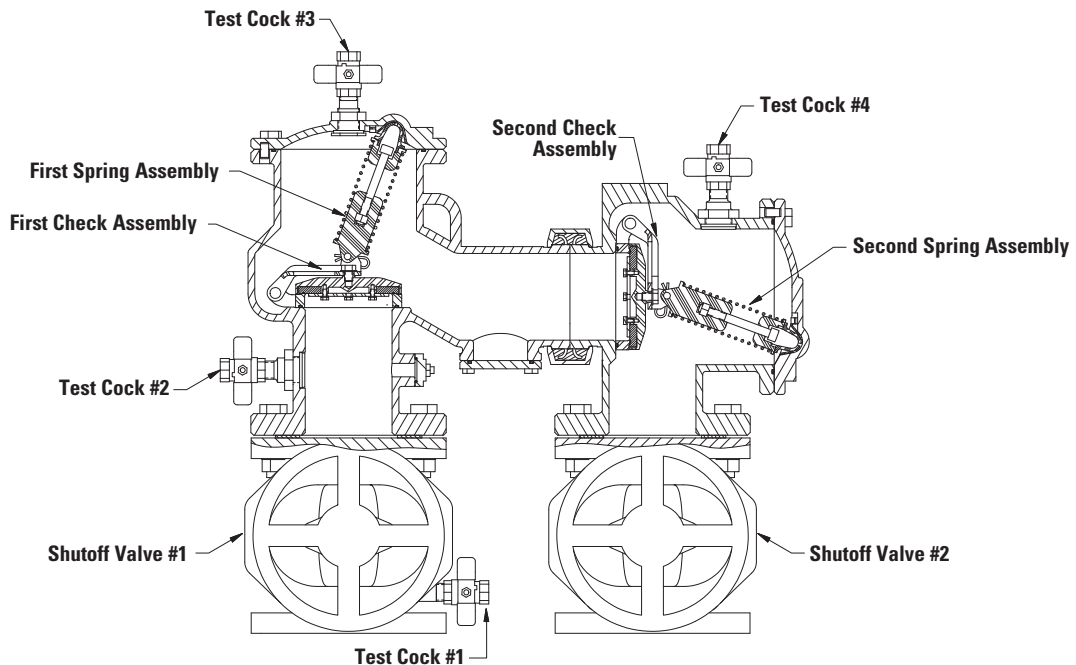

Dimensions – Weights

Below are the nominal dimensions and physical weights for the Model LF870V size 2½" through 8". Allowances must be made for normal manufacturing tolerances. Please visit our website to download a copy of this product's installation instructions, or contact your local FEBCO Representative for more information.

Model LF870V Standard Orientation (N-Pattern)

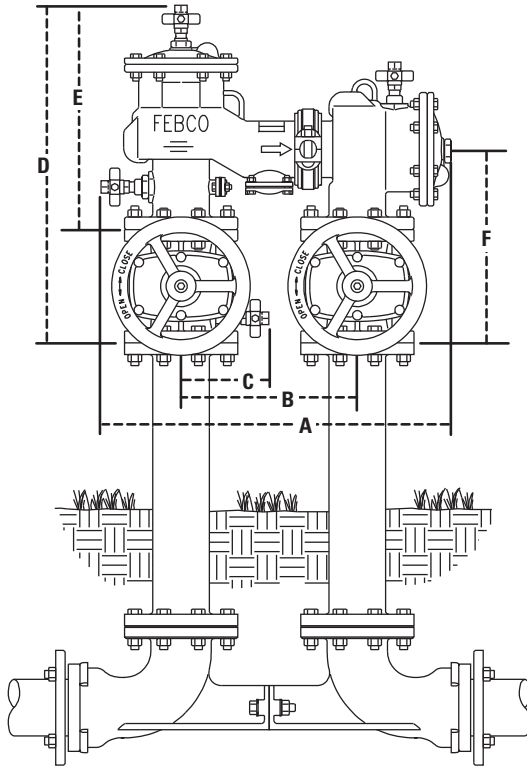

Note: The Model LF870V is shipped in the standard (N-Pattern) orientation as shown above.

Model LF870V Vertical Orientation (Z-Pattern)

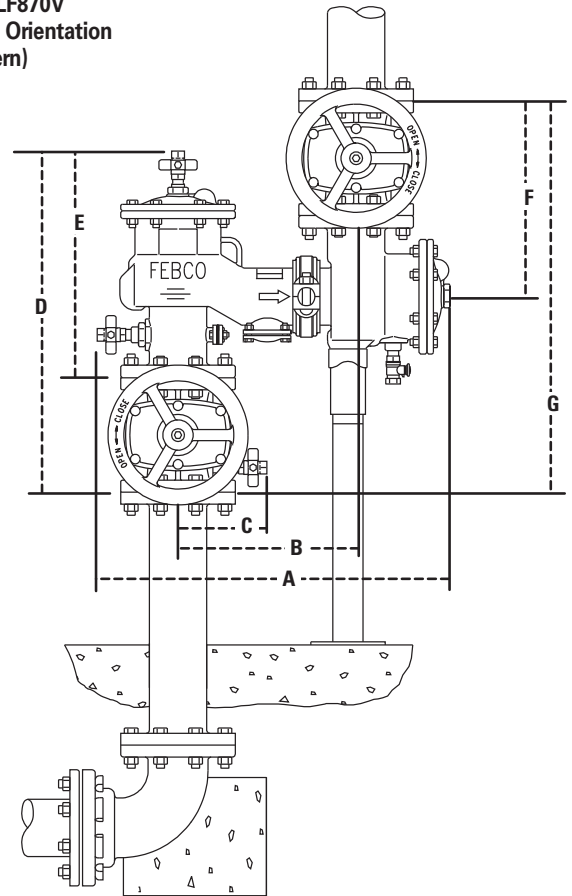

Gate Valve Side View Clearance

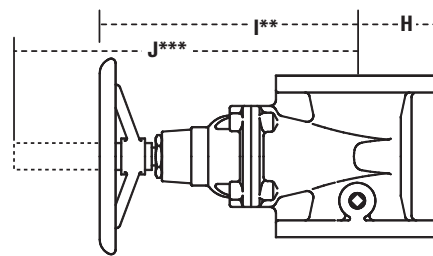

LF870V

SIZE (DN)		DIMENSIONS														WEIGHT****									
		A		B		C		D		E		F		G		H		I**		J***		NRS		OSY	
in.	mm	in.	mm	in.	mm	in.	mm	in.	mm	in.	mm	in.	mm	in.	mm	in.	mm	in.	mm	in.	mm	lbs.	kg.	lbs.	kg.
2½	65	25¾	654	12½	318	6¼	159	24¼	616	16½	422	13¾	346	27¼	692	3½	89	12¾	321	16¾	416	197	89	201	91
3	80	25¾	654	12½	318	6¼	159	24¼	629	16¾	422	14½	359	28¼	718	3¾	95	12¾	327	22¼	565	223	101	227	103
4	100	27⅞	708	14	356	7	178	26¾	680	17¾	451	15½	394	31	787	4½	114	14¾	365	23¼	591	320	145	332	151
6	150	32¼	819	16	406	8	203	32¼	819	21½	548	18¾	473	37¼	946	5½	140	18¾	479	30¾	765	492	223	512	232
8	200	37½	953	18½	470	9¼	235	36¾	932	24¾	632	20¾	527	41½	1054	6¼	172	23½	597	37¾	959	782	355	810	367

Notes:

** Indicates nominal dimensions with NRS Gate Valves

*** Indicates nominal dimensions with OSY Gate Valves (Full Open Position)

**** Indicates weight of complete Backflow Assemblies with specified Gate Valves

Performance

Flow capacity chart identifies valve performance based upon rated water Velocity up to 20fps

- Maximum service flow rate is determined by maximum rated Velocity of 7.5fps.
- AWWA Manual M-22 (Appendix C) recommends that the maximum water Velocity in the services be not more than 10fps.
- UL flow rate is determined by typically rated Velocity of 15 feet/sec.

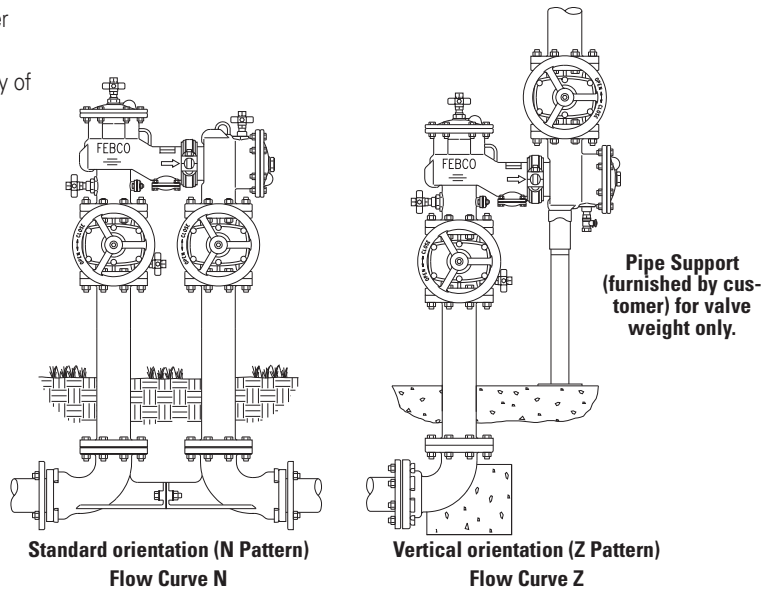

Capacity

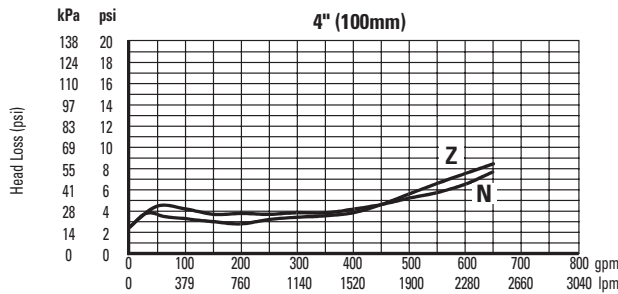
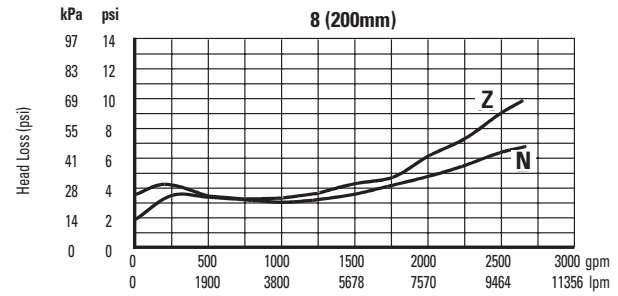
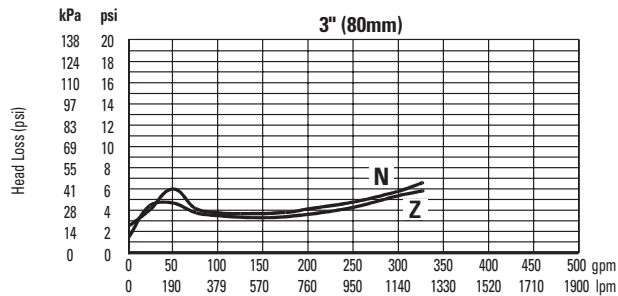
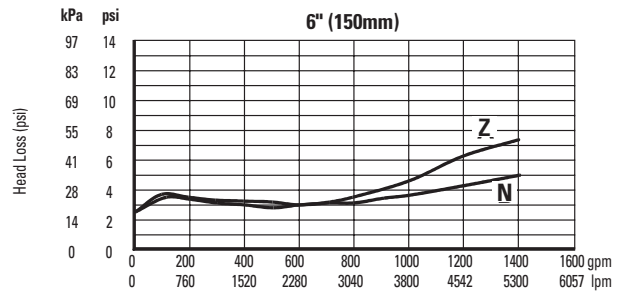
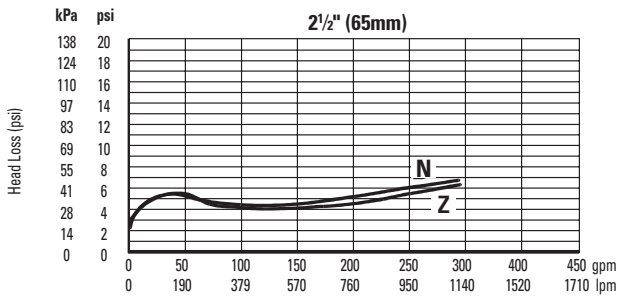

The 6" curves (N-standard orientation) include the FEBCO valve setter Series 611.



A Watts Water Technologies Company



USA: Tel: (800) 767-1234 • Fax: (800) 788-4491 • FEBCOonline.com
 Canada: Tel: (905) 332-4090 • Fax: (905) 332-7068 • FEBCOonline.ca
 Latin America: (52) 81-1001-8600 • Fax: (52) 81-8000-7091 • FEBCOonline.com