

**SPECIFICATION SHEET** **FEBCO**

**MASTER series**

**LEAD FREE\***

**MasterSeries® LF886V**  
**Reduced Pressure Zone**  
**Detector Backflow Prevention**  
**Assemblies (Type-II)**

**Size: 2½" - 8" (65mm - 200mm)**

The FEBCO MasterSeries LF886V Reduced Pressure Zone Detector Assembly is specifically designed to protect against possible backpressure and backsiphonage conditions for high hazard [i.e., toxic] application in accordance with Local Governing Water Utility Codes. This Backflow Assembly is primarily used on potable drinking water systems where Local Governing Codes mandate protection from non-potable quality water being pumped or siphoned back into the potable water system.

The LF886V features Lead Free construction to comply with low lead installation requirements. The Lead Free Reduced Pressure Zone Detector Assemblies shall comply with state codes and standards, where applicable, requiring reduced lead content.

**Features**

**Main Valve:**

- Inline Serviceable Assembly
- No Special Tools Required for Servicing
- Captured Modular Spring Assembly
- Reversible & Replaceable Discs
- Field Replaceable Seats
- Ductile Iron Valve Body Design
- Stainless Steel Check Components
- Modular Pressure Differential Relief Valve
- Repairable Pressure Differential Relief Valve
- Clapper Check Assembly
- Captured O-ring Design

**Auxiliary Bypass:**

- Compact Bypass Design; Remains within Main Valve Assembly Profile
- Inline Serviceable ¾" Backflow Assembly
- No Special Tools Required for Servicing
- Field Replaceable Seats & Discs
- Detect Potential Underground Water Leaks
- Detect Unauthorized Water Usage



**Model LF886V-OSY**

**Specifications**

The FEBCO MasterSeries LF886V Reduced Pressure Zone Detector Assembly shall be installed on the potable water supply and at each point of cross-connection to protect against possible backpressure and backsiphonage conditions for high hazard (i.e., toxic) applications. The assembly shall consist of a main line valve body composed of two (2) independently acting approved clapper style check modules with replaceable seats and disc rubbers. Servicing of both check modules does not require any special tools and are accessed through independent top entry covers. This assembly shall be fitted with approved UL/FM inlet/outlet resilient seated shutoff valves and contain four (4) properly located resilient seated test cocks as specified by AWWA Standard C511. The auxiliary bypass line contains a 5/8" x 3/4" (16 x 19mm) Water Meter that complies with ANSI/AWWA Standard C700 coupled with an approved check assembly compliant to AWWA Standard C511. The bypass line is designed to detect leaks or unauthorized water usage of the water system while protecting against possible backpressure and backsiphonage conditions for high hazard (i.e., toxic) applications. Flow and pressure loss performance parameters shall meet the requirements of AWWA Standard C511.

**NOTICE**

The information contained herein is not intended to replace the full product installation and safety information available or the experience of a trained product installer. You are required to thoroughly read all installation instructions and product safety information before beginning the installation of this product.

**NOTICE**

Inquire with governing authorities for local installation requirements

**\*The wetted surface of this product contacted by consumable water contains less than 0.25% of lead by weight.**

Job Name \_\_\_\_\_

Job Location \_\_\_\_\_

Engineer \_\_\_\_\_

Approval \_\_\_\_\_

Contractor \_\_\_\_\_

Approval \_\_\_\_\_

Contractor's P.O. No. \_\_\_\_\_

Representative \_\_\_\_\_

FEBCO product specifications in U.S. customary units and metric are approximate and are provided for reference only. For precise measurements, please contact FEBCO. FEBCO reserves the right to change or modify product design, construction, specifications, or materials without prior notice and without incurring any obligation to make such changes and modifications on FEBCO products previously or subsequently sold.

## Options - Suffix

- OSY: UL/FM Approved OS&Y Gate Valves [ANSI/AWWA C515 Compliant]  
 CFM: Totalizing Cubic feet/min 5/8" x 3/4" Water Meter [ANSI/AWWA C700 Compliant]  
 GPM: Totalizing Gallons/min 5/8" x 3/4" Water Meter [ANSI/AWWA C700 Compliant]  
 LG: Less Shutoff valves; This is NOT an APPROVED ASSEMBLY

### Example Ordering Description:

- 4" LF886V-OSY-GPM - Valve Assembly fitted with OS&Y Shutoff Valves & Gallons per Minute Water Meter  
 4" LF886VSOSY-CFM - Valve Assembly fitted with OS&Y Shutoff Valves & Cubic Feet per Minute Water Meter

### Available Components

- Wye Strainer:** FDA Approved [ASME B16.1 Class 125 & AWWA Class D Flange]  
**Series 611 Valve Setter:** MJ x MJ - Mechanical Joint x Mechanical Joint [AWWA C111/A21.11]  
 MJ x FL - Mechanical Joint x Flange [AWWA C111/A21.11; ASME B16.1 Class 125/ AWWA Class D Flange]  
 FL x FL - Flange x Flange [ASME B16.1 Class 125 & AWWA Class D Flange]

## Materials

- Main Valve Body: Ductile iron Grade 65-45-12  
 Relief Valve Body: Ductile iron Grade 65-45-12  
 Coating: Fusion epoxy coated internal and external AWWA C550-90  
 Shutoff Valves: OSY resilient wedge gate valve AWWA C515 (UL/FM)  
 Check Seats: Stainless Steel  
 Disc Holder: Stainless Steel  
 Elastomer Disc: Silicone  
 Spring: Stainless Steel  
 Clamp: AWWA C606

## Approvals – Standards:

- Foundation for Cross-Connection Control and Hydraulic Research at The University of Southern California [FCCCHR-USC]
- ASSE 1047
- \*\*UL Classified [US & Canada]
- \*\*FM
- IAPMO/cUPC



\*\*Assembly configured with UL/FM Approved OS&Y RW Gate Valves. Less gate valve assemblies are not UL/FM approved configurations.

## Assembly Flow Orientation:

- Horizontal (N-Pattern 2 1/2" – 8") - Approved by FCCCHR-USC, ASSE, cULus, FM, IAPMO/cUPC  
 Vertical Up (Z-Pattern 2 1/2" – 8") - Approved by FCCCHR-USC, ASSE, cULus, FM, IAPMO/cUPC

## Standards:

- AWWA Standard C511 Compliant
- End Connections: Compliant to ASME B16.1 Class 125 & AWWA Class D Flange

## Pressure - Temperature

- Max. Working Pressure: 175 psi (12.1 bar)  
 Min. Working Pressure: 20 psi (1.4 bar)  
 Hydrostatic Test Pressure: 350 psi (24.1 bar)  
 Hydrostatic Safety Pressure: 700 psi (48.3 bar)  
 Temperature Range: 33°F-140°F [0.5°C- 60°C] Continuous

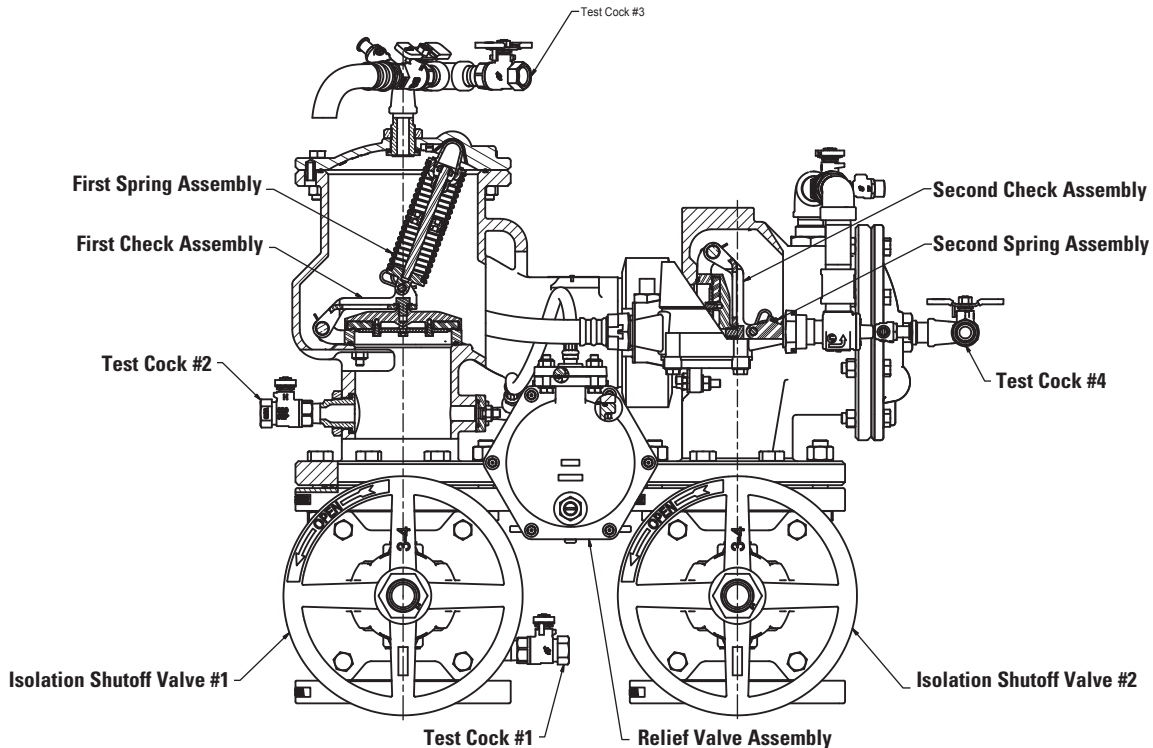

## Dimensions & Weights

Below are the nominal dimensions and physical weights for the Model 886 size 2½" through 8". Allowances must be made for normal manufacturing tolerances. Please visit our website to download a copy of this product's installation instructions, or contact your local FEBCO Representative for more information.

**Model LF886V Standard Orientation (N-Pattern)**

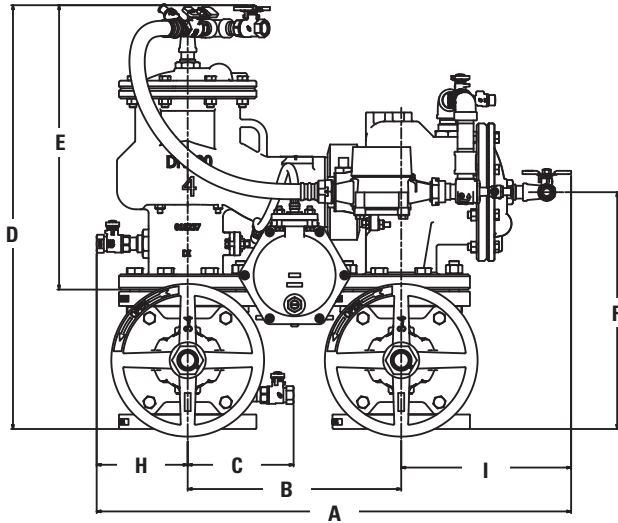

**Model LF886V Vertical Orientation (Z-Pattern)**

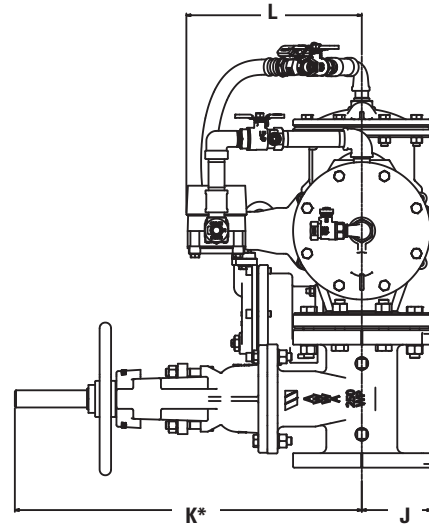
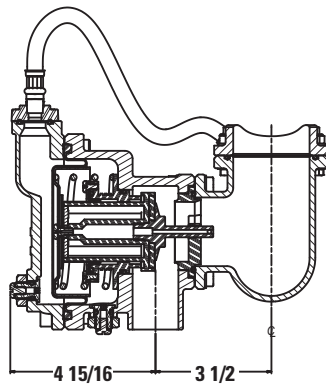
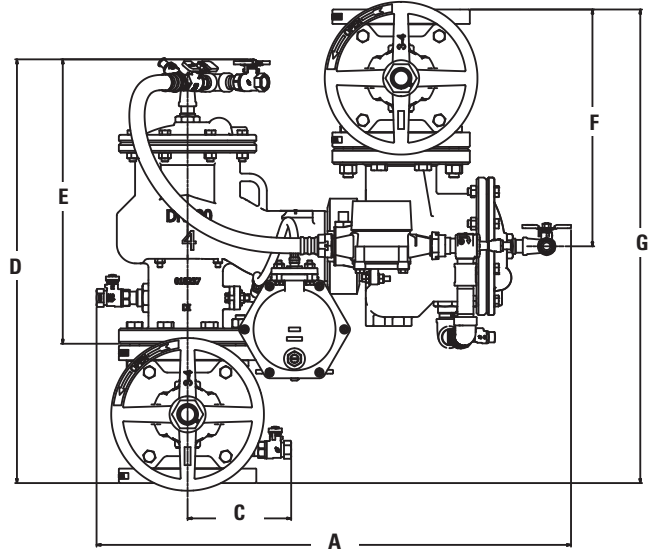

### MODEL LF886V ASSEMBLIES

SIZE (DN)		DIMENSIONS												WEIGHT**													
in.	mm	A		B		C		D		E		F		G		H		I		J		K*		L		lbs.	kg.
2½	65	29⅞	740	12½	318	6¼	159	25¼	642	17½	445	13⅝	346	27¼	692	5½	140	11⅞	283	3½	89	16⅜	416	11½	292	240	109
3	80	29⅞	740	12½	318	6¼	159	25¼	654	17¾	451	14⅞	359	28¼	718	5½	140	11⅞	283	3¾	95	22¼	565	11½	292	267	121
4	100	31⅞	791	14	356	7	178	27¾	705	18¾	476	15½	394	31	787	6	152	11⅞	283	4½	114	23¼	591	13	330	342	155
6	150	35¾	908	16	406	8	203	32¾	831	22⅞	562	18⅞	473	37¼	946	7¼	184	12½	316	5½	140	30⅞	765	13	330	530	240
8	200	40¾	1035	18½	470	9¼	235	36¾	933	25⅞	638	20¾	527	41½	1054	8½	216	14	356	6¾	172	37¾	959	14½	368	846	384

#### Notes:

\* Indicates nominal dimensions with OSY Gate Valves (Full Open Position)

\*\* Indicates weight of complete Backflow Assemblies with specified Gate Valves

The gap drain is not designed to catch the maximum discharge possible from the relief valve. The installation of the FEBCO air gap with the drain line terminating above a floor drain will handle any normal discharge or nuisance spitting through the relief valve. However, floor drain size may need to be designed to prevent water damage caused by a catastrophic failure condition. Do not reduce the size of the drain line from the air gap fitting.

# Performance

Flow capacity chart identifies valve performance based upon rated water Velocity up to 20fps

- Maximum service flow rate is determined by maximum rated Velocity of 7.5fps.
- AWWA Manual M-22 [Appendix C] recommends that the maximum water Velocity in the services be not more than 10fps.
- UL flow rate is determined by typically rated Velocity of 15 feet/sec.

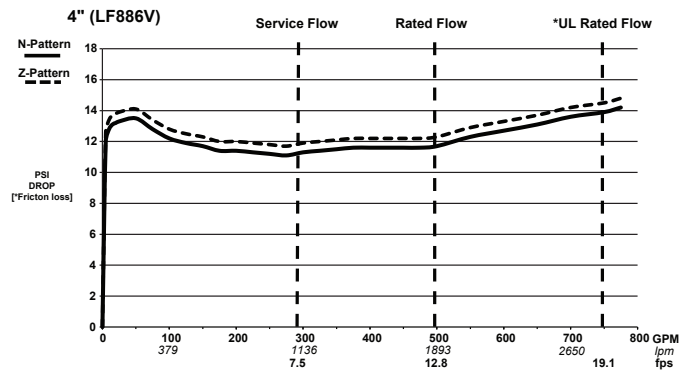
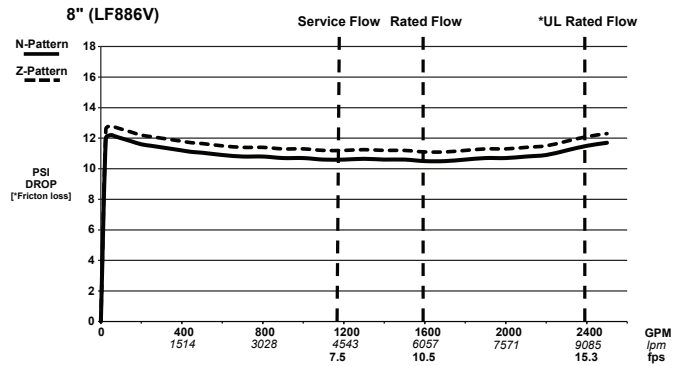
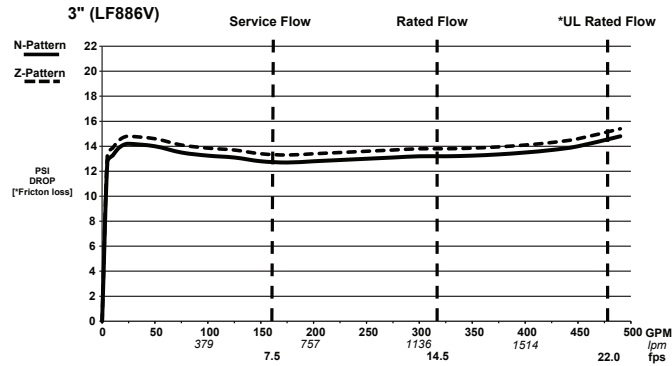
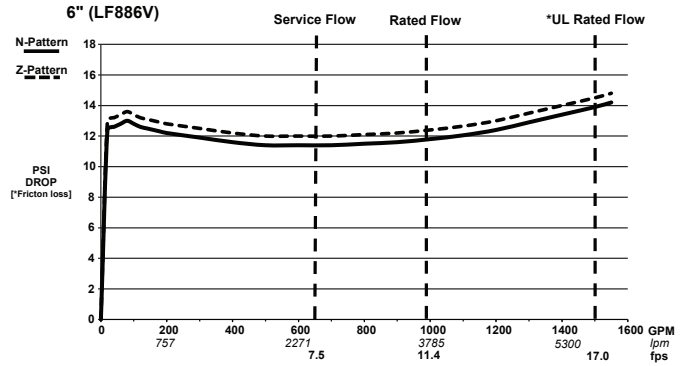
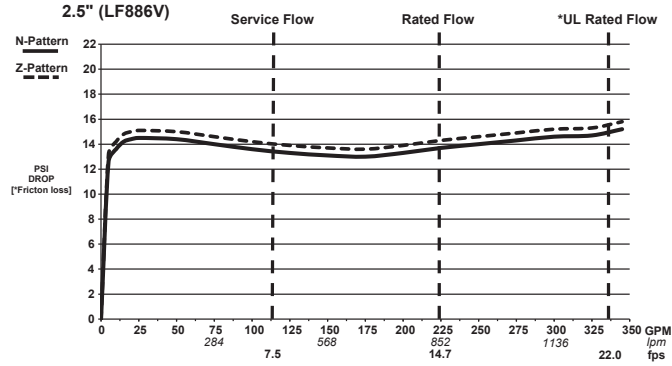

A Watts Water Technologies Company

USA: Tel: (800) 767-1234 • Fax: (800) 788-4491 • FEBCOnline.com  
 Canada: Tel: (905) 332-4090 • Fax: (905) 332-7068 • FEBCOnline.ca  
 Latin America: Tel: (52) 81-1001-8600 • FEBCOnline.com