

Model RP-1

2" - 10"

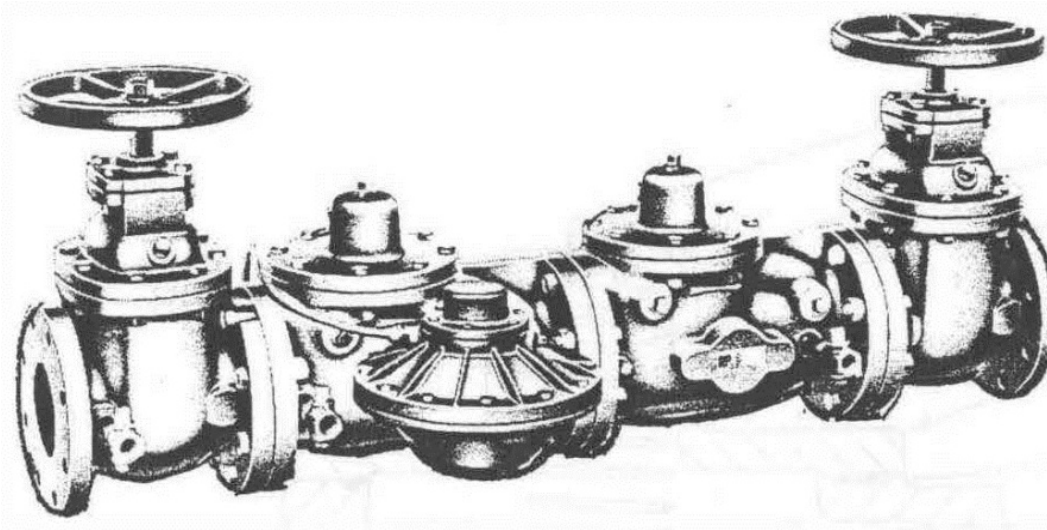

American Backflow
Products Company



Product Overview

RP-1 (1978-1985) Utilized the 3081 Toggle Lever Checks and CDHS-20 relief valve.

Replacement hardware parts were discontinued in 2005. Only repair kits with rubber parts are available.

Check Cover Removal

The check covers are secured by bolts and sealed by an o-ring.

2" through 6" sizes remove all but two cover bolts, leaving two bolts 180 degrees apart. Press down on the cover while removing the last two bolts to prevent the cover from being forcibly ejected by the spring.

8" and 10 sizes, it is suggested that all-thread rod and nuts (jack screws) be used when removing or replacing the covers. The 8" size uses two 5/8"-11 all-thread approximately 8" long. The 10" size uses two 3/4" -10 approximately 8" long. Remove two cover bolts on opposite sides of the cover, and install all-thread rod. Install and tighten nuts down to cover. Remove remaining cover bolts. Simultaneously, back the jack screw nuts off until the spring tension is completely released. Remove the cover.

Check Valve Removal

Remove the two pipe plugs on each side of the valve body, to expose the lever arm pin (item 13) and the hinge pin (item 11).

Using a brass rod (smaller in diameter than the pins), gently tap out the rear lever arm (item 13) pin first.

CAUTION: Support the lever arm (item 10) while completely removing the lever arm pin. Let the lever arm rest gently in the bottom of the check valve.

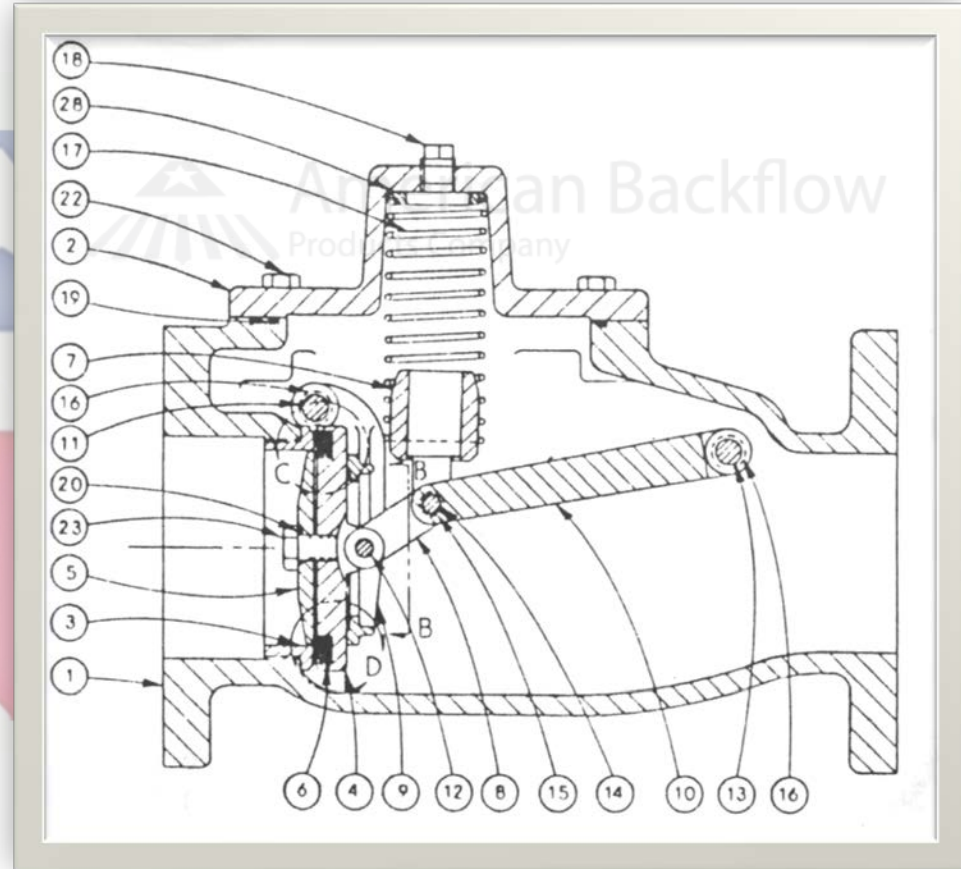

Check Valve Removal

Grasp the yoke (item 7) with one hand, while removing the front hinge pin (item 11). Lift out the toggle - lever clapper assembly, being careful that the brass seat is not dented.

On 8" and 10" sizes, a lever arm spacer (item 26) is installed between the two lever arms to maintain proper distance between them, and prevent binding.

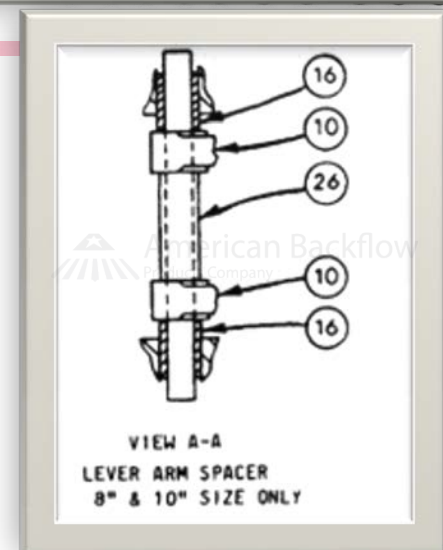
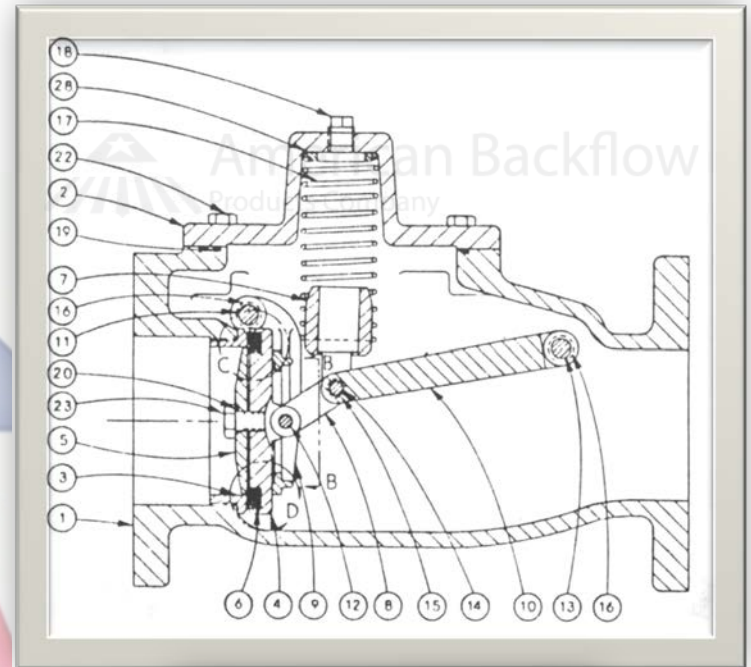

Check Valve Disassembly

2" through 8" sizes remove the retaining bolt (item 23) from the center of the disc guide.

10" sizes (only) remove sixteen retaining screws from the disc guide (item 5).

The check disc is free once the guide is separated from the disc retainer (item 4).

An o-ring (item 20) is installed on the retaining bolts for sizes 2 1/2", 3", 4", 6" and 8".

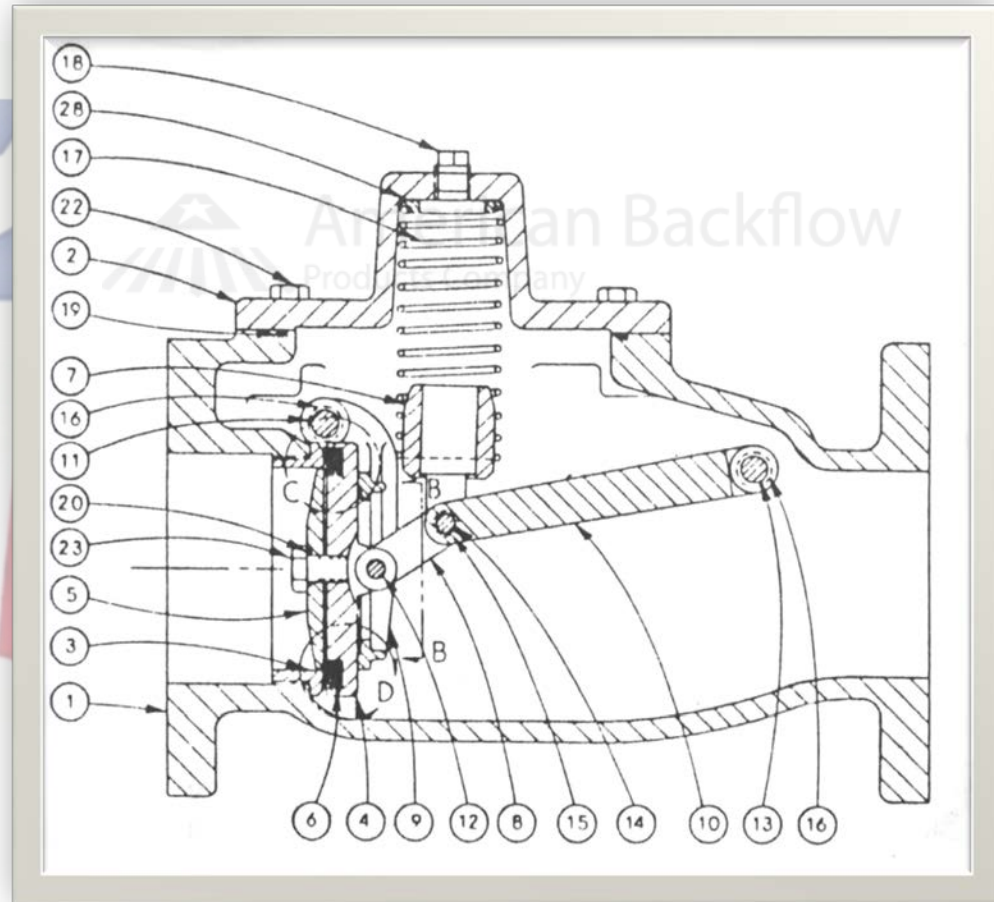

Check Seat Service

Check seats are o-ring sealed and pressed into the body.

Replacement seats are no longer in production.

Very fine nicks on the seating edge can be restored by slowly working 400 wet or dry sandpaper back and forth on both sides (top and inner throat) of the seat.

Check Disc Replacement

When installing a new check disc, fiber spacer washers between the retainer and guide MAY or MAY NOT be required.

Fiber spacer washers (item 33) are installed to ensure the proper “squeeze” on the disc (item 6).

Too many washers will not allow sufficient squeeze on the disc (not a water tight seal). This will cause the check valve to fail.

Too few washers between the guide and retainer can generate TOO MUCH squeeze on the disc, causing it to bulge around the guide. This will also cause the check to fail.

Proper squeeze on the disc is achieved when the disc cannot be rotated and no bulge appears.

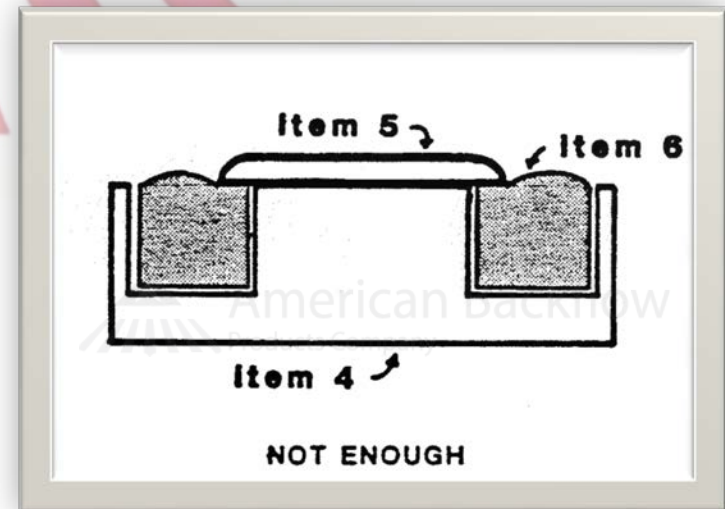

Check Valve Alignment

Re-install clapper assembly. Be careful not to damage check seat.

Support clapper assembly with one hand and install hinge pin.

With clapper assembly supported by hinge pin only, exert pressure to force disc against the seat, and leave an imprint of the seat in the disc.

Remove clapper assembly. Inspect disc to ascertain that alignment is correct.

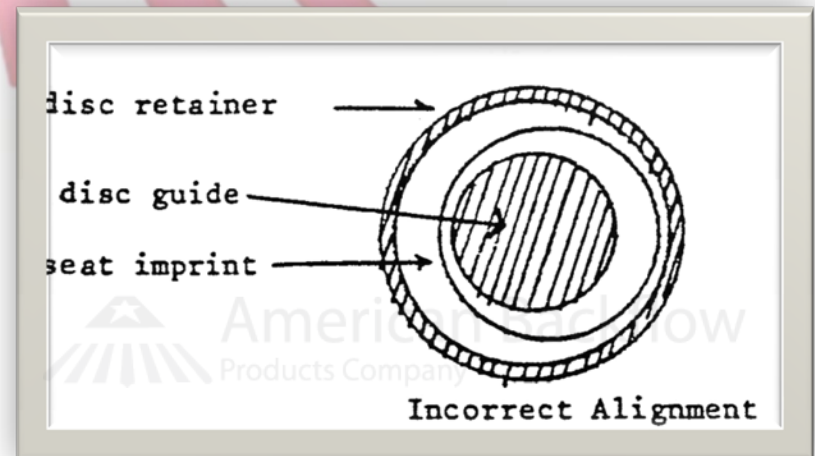
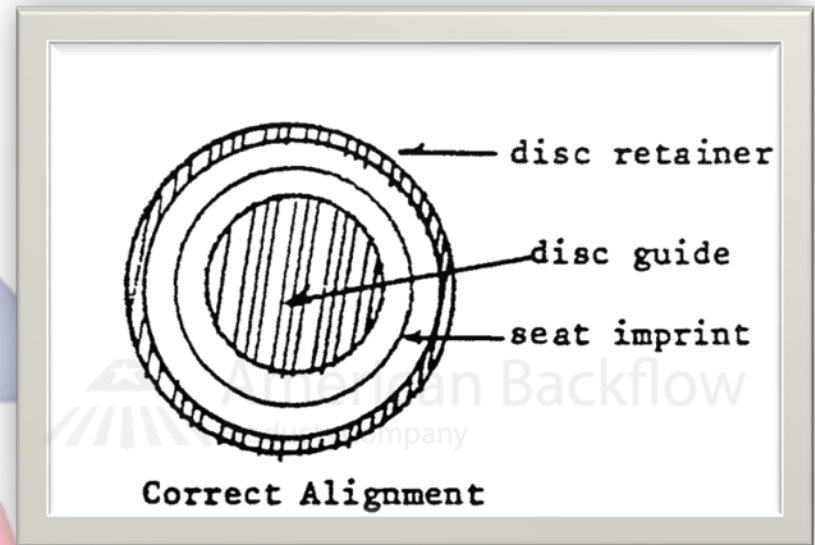

Check Valve Alignment

In the event the seat imprint indicates an incorrect alignment, adjust hinge pin bushing OUT, on the side that corresponds to the least distance between the seat imprint and disc guide.

In this figure, adjust hinge pin bushing on the RIGHT side outward.

Alignment is correct if the seat leaves an imprint on the disc equidistant on all sides of the disc guide.

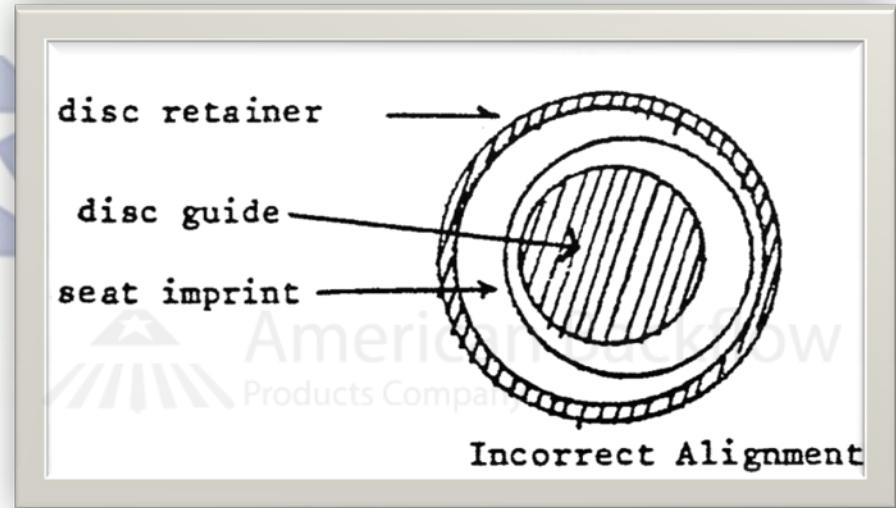

Check Reassembly Notes

When the two pins that hold the toggle-lever (clapper) assembly are installed, be sure to note that the yoke (item 7) and the lever arm pivots upward freely.

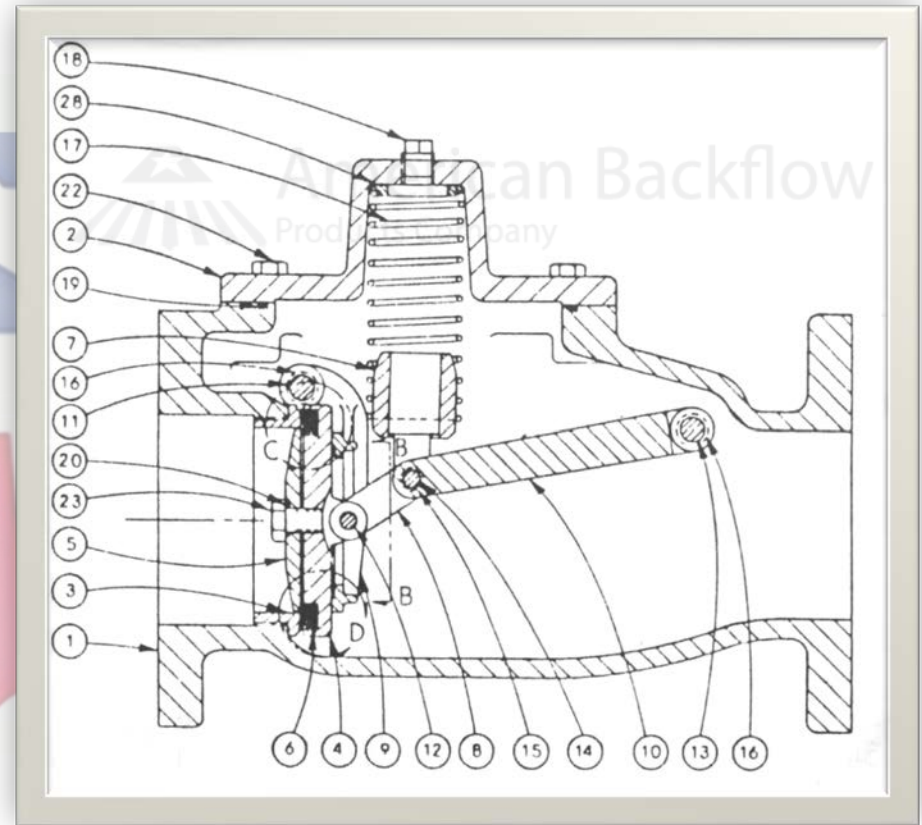

Relief Valve Cover Removal

The CDHS-20/ CDHS-24 RV has two covers. The belloram cover (item 3) and the intermediate body or “diaphragm cover” (item 2).

The belloram cover (item 3) is located on top of the RV assembly.

The belloram cover is secured by screws and sealed by the belloram.

There is no spring load on this cover.

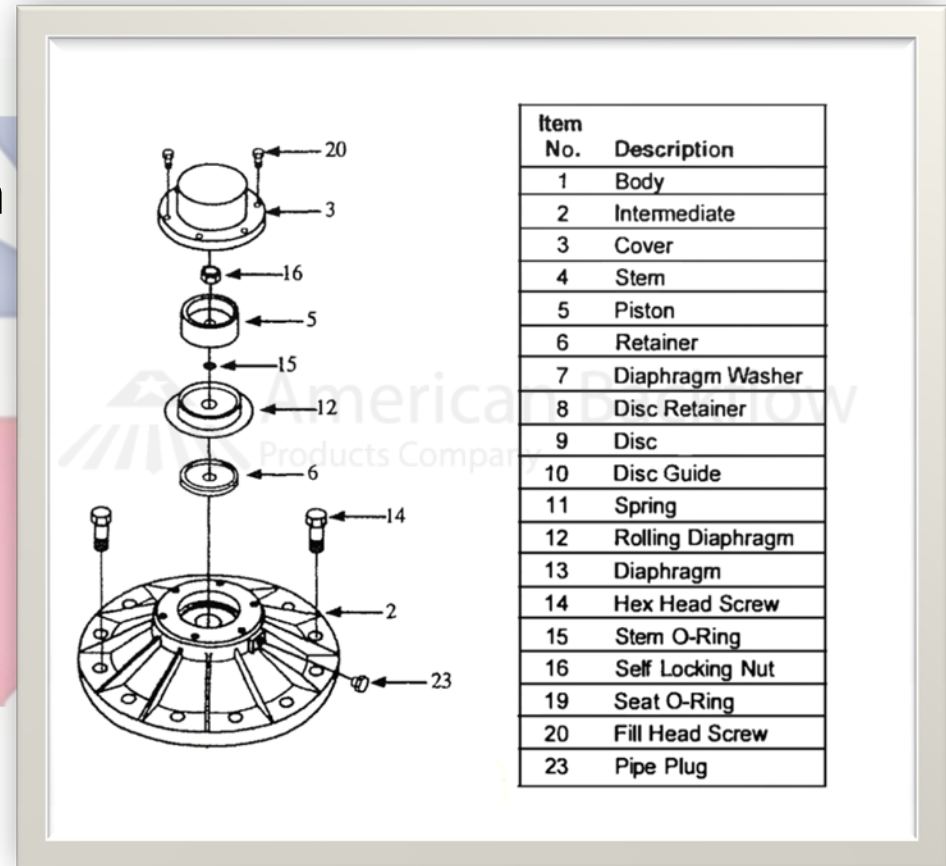

Relief Valve Cover Removal

The intermediate body (item 2) is secured by cap screws and sealed by the diaphragm.

There is a slight spring load on this cover, so exert pressure downward on the cover as the cap screws are removed.

The RV stem assembly is mounted through the intermediate body.

The RV spring is free once cover is removed.

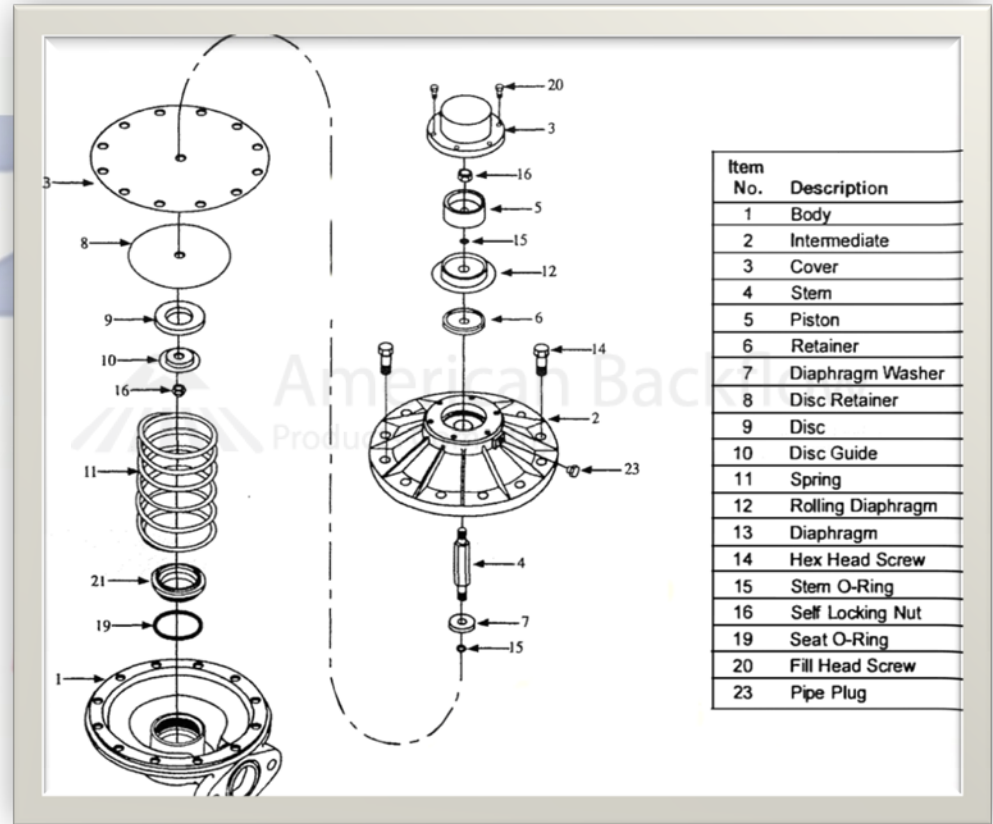

Disassemble RV Stem

The stem is secured by the upper and lower stem nuts (item 16).

Remove the upper stem nut first.

The bellofram, piston and retainer can now be removed from the upper stem.

Remove the stem along with the diaphragm and disc from the body.

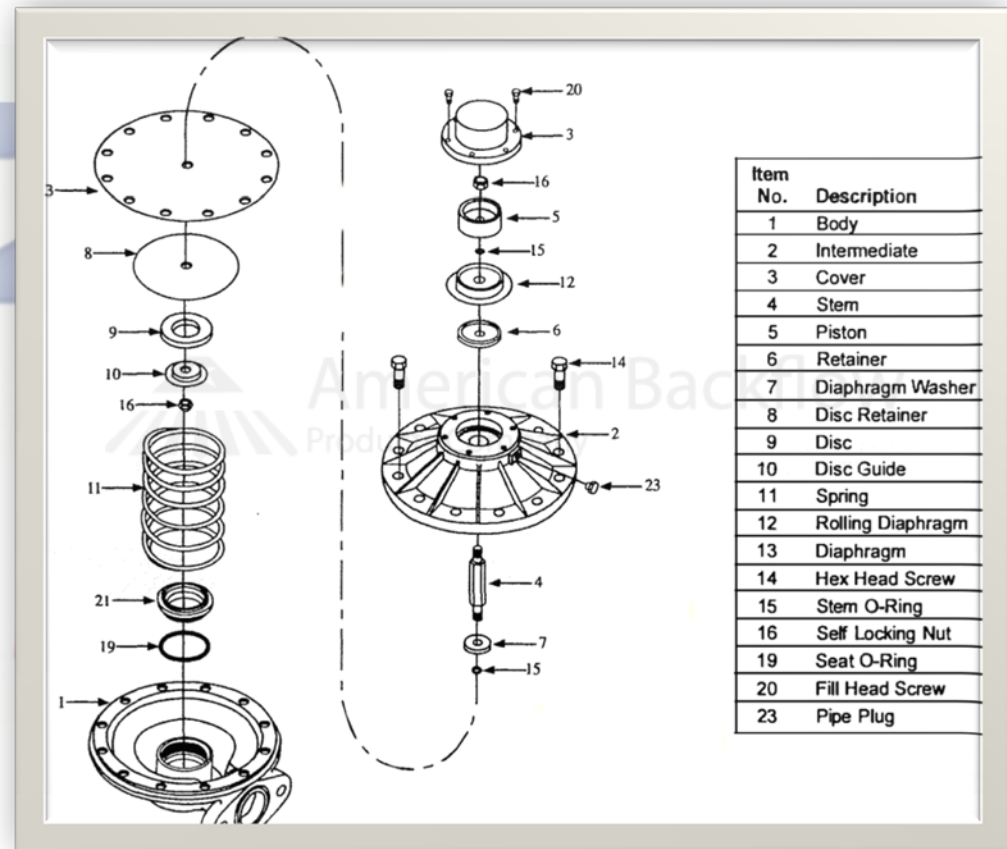

Disassemble RV Stem

Remove lower stem nut (item 16).

The RV disc (9), disc retainer (8), and guide (10) are removed as one assembly. (Simply pry disc from retainer)

Remove the diaphragm (item 13), the lower stem o-ring (item 15) and washer (item 7) from stem.

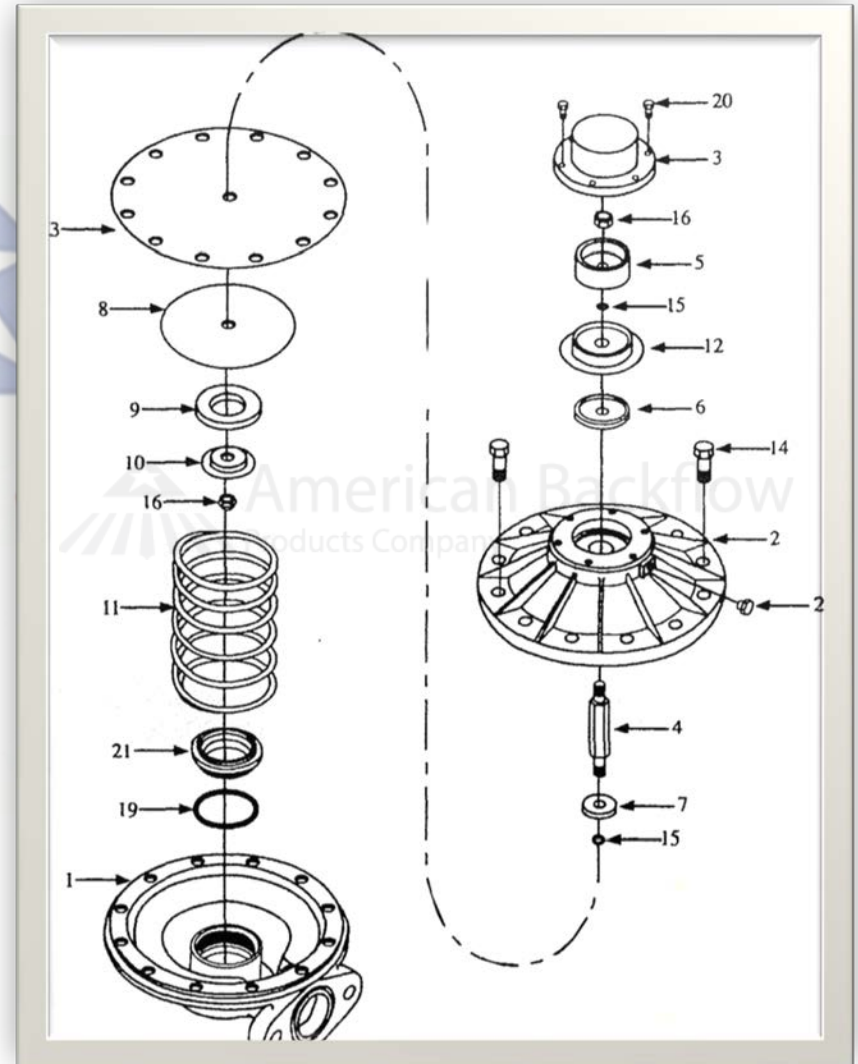

RV Seat Service

The RV seat is o-ring sealed and threaded into the main RV body.

Replacement seats are no longer in production.

Very fine nicks on the seating edge can be restored by slowly working 400 wet or dry sandpaper back and forth on both sides (top and inner throat) of the seat.

Diaphragm Reassembly

Reassemble the diaphragm (item 13), lower stem o-ring (item 15) and washer (item 7) on the lower stem (4).

Reassemble the RV disc, disc retainer, and guide as one assembly on the lower stem.

The serrated area of the disc retainer (8) is positioned against the diaphragm.

Insert the stem (4) with diaphragm and disc retainer intact, into the intermediate body.

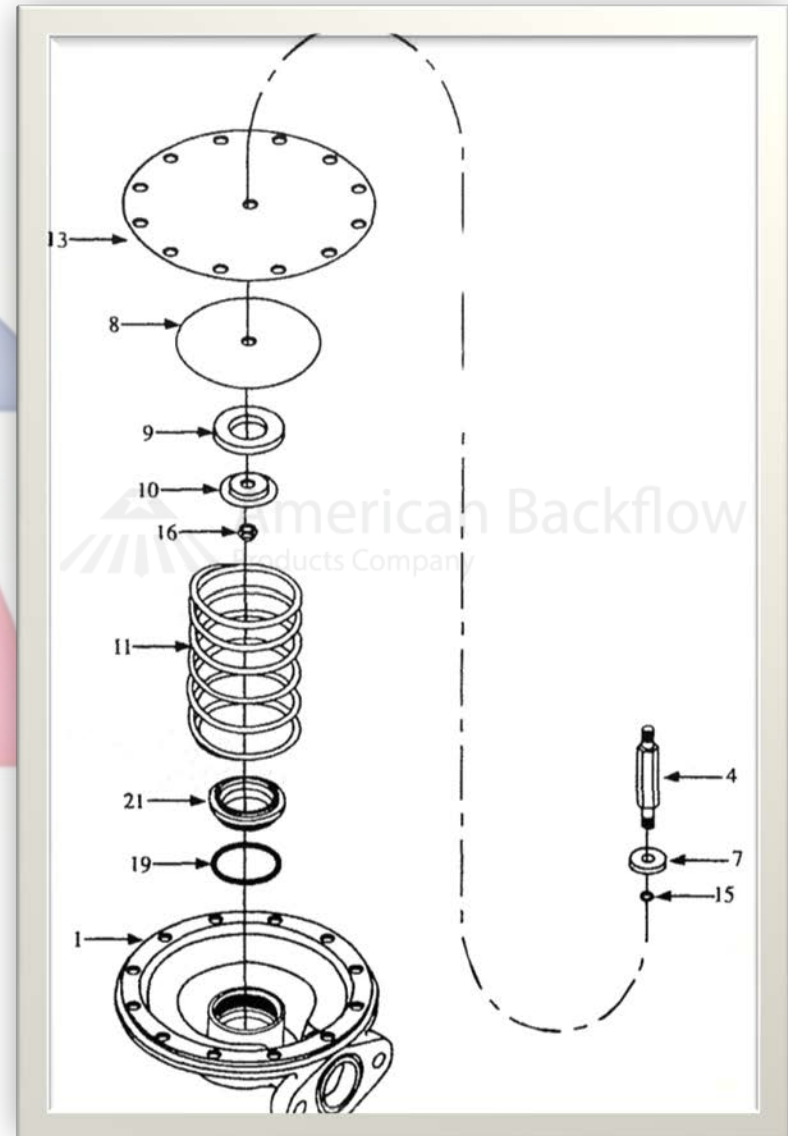

Upper Stem Reassembly

Reassemble the bellofram (12), piston (5), retainer (6) and stem o-ring (15) on the upper stem and replace stem nut.

Position the retainer (6) with its outer lip facing up.

Position the bellofram with the glossy side against the retainer(6). The fabric side against the piston(5)

Position the piston (5) with the recess around the stem hole facing down toward the o-ring (15).

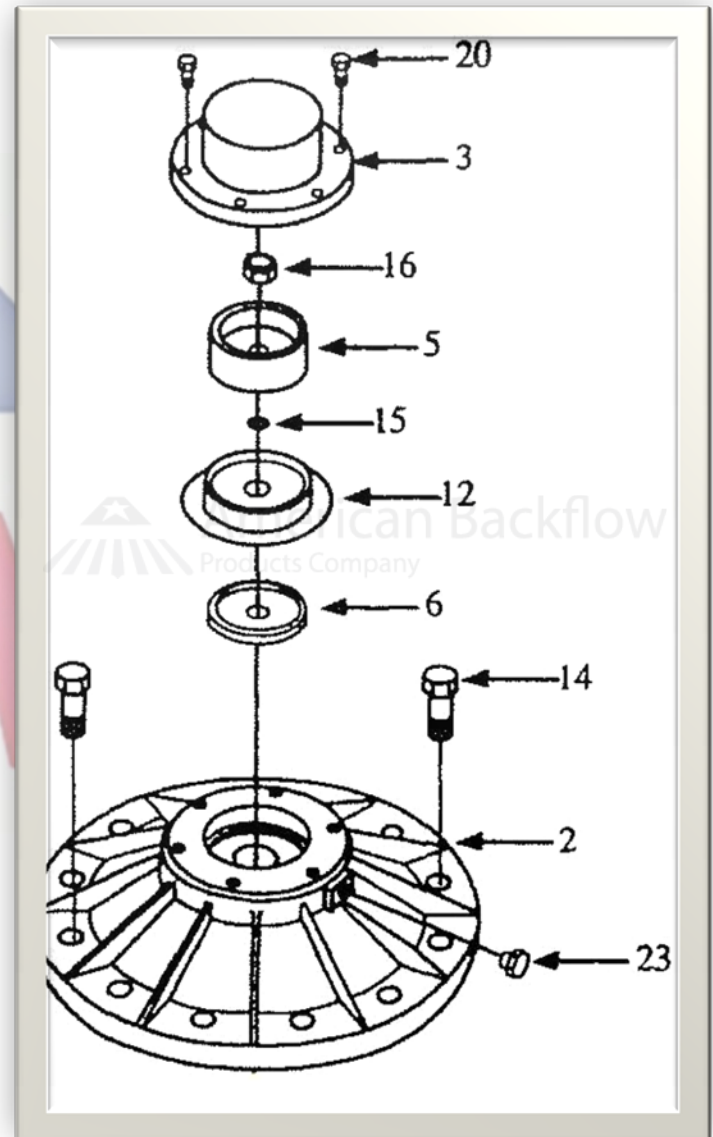

Intermediate Body Reassembly

Position the RV spring over the seat in the main body.

Insert cap screws through intermediate body and diaphragm. Make sure the sensing passage is aligned properly.

Press the intermediate body down on the main body and start cap screws.

Be sure to evenly cross tighten cap screws.

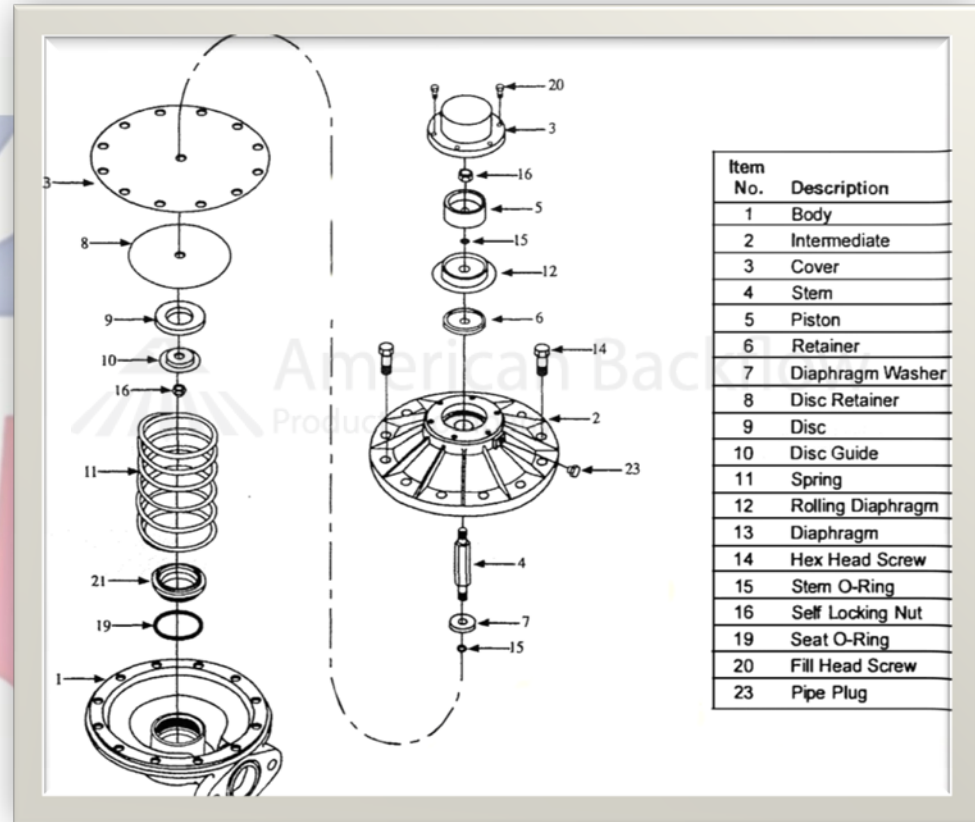

Bellofram Reassembly

Carefully push bellofram(12)
“brim” straight down over itself
so that the “brim” is flat and
smooth against the
intermediate body.

Make sure the bellofram is not
twisted or wrinkled.

Install cover (3) so that weep
hole faces out away from
backflow.

Do not rotate cover after
placing over the “brim”, this can
twist and tear the bellofram.

